

USER MANUAL

Geo Brick



Programmable Servo Amplifier

5xx-603800-xUxx

February 13, 2008



DELTA TAU
Data Systems, Inc.

NEW IDEAS IN MOTION ...

Copyright Information

© 2008 Delta Tau Data Systems, Inc. All rights reserved.

This document is furnished for the customers of Delta Tau Data Systems, Inc. Other uses are unauthorized without written permission of Delta Tau Data Systems, Inc. Information contained in this manual may be updated from time-to-time due to product improvements, etc., and may not conform in every respect to former issues.

To report errors or inconsistencies, call or email:

Delta Tau Data Systems, Inc. Technical Support

Phone: (818) 717-5656

Fax: (818) 998-7807

Email: support@deltatau.com

Website: <http://www.deltatau.com>

Operating Conditions

All Delta Tau Data Systems, Inc. motion controller products, accessories, and amplifiers contain static sensitive components that can be damaged by incorrect handling. When installing or handling Delta Tau Data Systems, Inc. products, avoid contact with highly insulated materials. Only qualified personnel should be allowed to handle this equipment.

In the case of industrial applications, we expect our products to be protected from hazardous or conductive materials and/or environments that could cause harm to the controller by damaging components or causing electrical shorts. When our products are used in an industrial environment, install them into an industrial electrical cabinet or industrial PC to protect them from excessive or corrosive moisture, abnormal ambient temperatures, and conductive materials. If Delta Tau Data Systems, Inc. products are directly exposed to hazardous or conductive materials and/or environments, we cannot guarantee their operation.

Safety Instructions

Qualified personnel must transport, assemble, install, and maintain this equipment. Properly qualified personnel are persons who are familiar with the transport, assembly, installation, and operation of equipment. The qualified personnel must know and observe the following standards and regulations:

IEC 364 resp. CENELEC HD 384 or DIN VDE 0100

IEC report 664 or DIN VDE 0110

National regulations for safety and accident prevention or VBG 4

Incorrect handling of products can result in injury and damage to persons and machinery. Strictly adhere to the installation instructions. Electrical safety is provided through a low-resistance earth connection. It is vital to ensure that all system components are connected to earth ground.

This product contains components that are sensitive to static electricity and can be damaged by incorrect handling. Avoid contact with high insulating materials (artificial fabrics, plastic film, etc.). Place the product on a conductive surface. Discharge any possible static electricity build-up by touching an unpainted, metal, grounded surface before touching the equipment.

Keep all covers and cabinet doors shut during operation. Be aware that during operation, the product has electrically charged components and hot surfaces. Control and power cables can carry a high voltage, even when the motor is not rotating. Never disconnect or connect the product while the power source is energized to avoid electric arcing.

After removing the power source from the equipment, wait at least 10 minutes before touching or disconnecting sections of the equipment that normally carry electrical charges (e.g., capacitors, contacts, screw connections). To be safe, measure the electrical contact points with a meter before touching the equipment.

The following text formats are used in this manual to indicate a potential for personal injury or equipment damage. Read the safety notices in this manual before attempting installation, operation, or maintenance to avoid serious bodily injury, damage to the equipment, or operational difficulty.

WARNING:

A Warning identifies hazards that could result in personal injury or death. It precedes the discussion of interest.

Caution:

A Caution identifies hazards that could result in equipment damage. It precedes the discussion of interest

Note:

A Note identifies information critical to the user's understanding or use of the equipment. It follows the discussion of interest.

REVISION HISTORY

REV.	DESCRIPTION	DATE	CHG	APPVD
1	UPDATED ANALOG INPUT SECTION	09/07/06	CP	R. UNADKAT
2	UPDATED 6-AXIS REGEN RESISTOR INFO, P. 8	03/19/07	CP	D. GENTRY
3	UPDATED PART NUMBER DEFINITION TABLE, P. 7	04/27/07	CP	S. SATTARI
4	UPDATED TROUBLESHOOTING CHAPTER, P. 75	09/12/07	CP	R. NADDAF
5	UPDATED TROUBLESHOOTING CHAPTER, P. 75	02/13/08	CP	R. NADDAF

Table of Contents

Copyright Information.....	ii
Operating Conditions.....	ii
Safety Instructions.....	ii
INTRODUCTION.....	1
Geo Brick Features.....	1
<i>Amplifier Standard Features</i>	2
<i>Amplifier Ratings</i>	2
Feedback Devices.....	3
Compatible Motors.....	3
<i>Maximum Speed</i>	3
<i>Torque</i>	3
<i>Motor Poles</i>	4
<i>Motor Inductance</i>	4
<i>Motor Resistance</i>	4
<i>Motor Back EMF</i>	4
<i>Motor Torque Constant</i>	4
<i>Motor Inertia</i>	5
<i>Motor Cabling</i>	5
SPECIFICATIONS.....	7
Part Number.....	7
<i>Geo Brick Options</i>	7
Environmental Specifications.....	8
Electrical Specifications.....	8
<i>4-axis Configuration</i>	8
<i>6-axis Configuration</i>	9
<i>8-axis Configuration</i>	9
Recommended Fusing and Wire Gauge.....	10
<i>Wire Sizes</i>	10
Package Types.....	10
RECEIVING AND UNPACKING.....	11
Use of Equipment.....	11
MOUNTING.....	13
4-axis Low/Medium Power Drive.....	14
6-axis: 4-axis Low/Medium Power plus 2-axis High Power (15A/30A) Drive.....	15
8-axis Low/Medium Power Drive.....	16
SYSTEM WIRING.....	17
<i>Fuse and Circuit Breaker Selection</i>	17
<i>Use of GFI Breakers</i>	18
<i>Transformer and Filter Sizing</i>	18
<i>Noise Problems</i>	18
<i>Operating Temperature</i>	18
<i>Single Phase Operation</i>	18
Wiring AC Input.....	19
<i>J1: AC Input Connector Pinout</i>	19
Wiring Earth-Ground.....	19
<i>Earth Grounding Paths</i>	19
Wiring 24 V Logic Control.....	20
<i>J2: 24VDC Input Logic Supply Connector</i>	20
Wiring the Motors.....	20
<i>A1-8: Motor 1 to 8 Output Connector Pinout (Low/Medium Power Units)</i>	21
<i>A5-6: Motor 5 and 6 High Power Option Connector Pinout</i>	21
Regen (Shunt) Resistor Wiring.....	21

<i>J3: External Shunt Connector Pinout</i>	22
<i>Shunt Regulation</i>	22
<i>Minimum Resistance Value</i>	23
<i>Maximum Resistance Value</i>	23
<i>Energy Transfer Equations</i>	23
Bonding.....	26
Filtering.....	26
<i>CE Filtering</i>	26
<i>Input Power Filtering</i>	26
<i>Motor Line Filtering</i>	27
<i>I/O Filtering</i>	27
Connectors.....	28
<i>X1-X8: Encoder Input (1 to 8)</i>	28
<i>X9-10: Analog I/O Ch5 (X9) and Ch6 (X10), (Optional)</i>	29
<i>X11-12: Analog I/O Ch7 (X11) and Ch8 (X12), (Optional)</i>	29
<i>X13: USB 2.0 Connector</i>	30
<i>X14: RJ45, Ethernet Connector</i>	30
<i>X15: Watchdog & ABORT</i>	31
<i>RS-232: RS-232 Serial Communication Port</i>	31
<i>JPWR Power 4-Point Screw Terminal (Internal)</i>	33
<i>Boot SW</i>	33
<i>Reset SW</i>	33
<i>J4 Limit Inputs (1-4 Axis)</i>	34
<i>J5 Limit Inputs (5-8 Axis)</i>	35
<i>J6: General Purpose I/O</i>	37
<i>Suggested M-Variable Addressing for the General Purpose I/O (J6)</i>	38
<i>J7: Extra General Purpose I/O (Optional)</i>	39
<i>Suggested M-Variable Addressing for the optional General Purpose I/O (J7)</i>	40
Setting up Quadrature Encoders.....	42
<i>Signal Format</i>	42
<i>Hardware Setup</i>	42
<i>Encoder Loss Setup</i>	43
Setting Up Digital Hall Sensors.....	44
<i>Signal Format</i>	44
<i>Hardware Setup</i>	44
<i>Using Hall Effect Sensors for Phase Reference</i>	45
<i>Determining the Commutation Phase Angle</i>	45
<i>Finding the Hall Effect Transition Points</i>	45
<i>Calculating the Hall Effect Zero Point (HEZ)</i>	46
<i>Determining the Polarity of the Hall Effects – Standard or Reversed</i>	48
<i>Software Settings for Hall Effect Phasing</i>	49
<i>Optimizing the Hall Effect Phasing Routine for Maximum Performance</i>	50
<i>Using the Test Results</i>	51
<i>Setting Up the Analog Inputs (optional)</i>	54
<i>Filtered DAC Outputs Configuration</i>	57
Setting up for Pulse and Direction Output.....	58
<i>Software Setup</i>	58
DIRECT PWM COMMUTATION CONTROLLER SETUP.....	62
Key Servo IC Variables.....	62
Key Motor Variables.....	62
DC BRUSH MOTOR DRIVE SETUP WITH TURBO PMAC	63
Commutation Phase Angle: I_{xx72}	63
Special Instructions for Direct-PWM Control of Brush Motors.....	63
Testing PWM and Current Feedback Operation.....	64
<i>Purpose</i>	65

Preparation.....	65
Position Feedback and Polarity Test.....	66
PWM Output and ADC Input Connection.....	66
PWM/ADC Phase Match.....	67
Synchronous Motor Stepper Action.....	67
Current Loop Polarity Check.....	67
Troubleshooting.....	67
Setting I ² T Protection.....	68
Calculating Minimum PWM Frequency.....	69
Amplifier Only Special online commands.....	70
AMPVERSION.....	70
AMPMOD.....	70
PWM DRIVE COMMAND STRUCTURE.....	73
Default Mode.....	73
Enhanced Mode.....	73
TROUBLESHOOTING.....	75
Error Codes.....	75
D1: Geo Brick Drive Status Display Codes.....	76
Status LEDs.....	77
Actions on Watchdog Timer Trip.....	77
Diagnosing Cause of Watchdog Timer Trip.....	78
APPENDIX A.....	80
Mating Connector and Cable Kits.....	80
CONKIT5A.....	81
CONKIT5B.....	81
CONKIT5C.....	81
PWM Cable Ordering Information.....	82
Cable Drawings.....	83
5A/10A and 8A/16A Motor Cable.....	83
15A/30A Motor Cable.....	84
24V Logic Power Cable.....	85
3-Phase power cable.....	86
Regenerative Resistor: GAR48/78.....	86
Regenerative Resistor: GAR48/78.....	87
DB- Connector Spacing Specifications.....	88
X1-8: DB-15 Connectors for encoder feedback.....	88
X9-12: DB-9 Connectors for Analog I/O.....	88
Screw Lock Size for all DB-connectors.....	88
Type of Cable for Encoder Wiring.....	89
APPENDIX B.....	91
Schematics.....	91
X15: Watchdog.....	91
J6 and J7: General Purpose I/O.....	91
J4: Limit Inputs for Axis 1-4.....	93
J5: Limit Inputs for Axis 5-8.....	94
APPENDIX C.....	95
Board Jumpers.....	95
E10 – E12: Power-Up/Reset Load Source.....	95
E13: Firmware Reload Enable.....	95
E14: Watchdog Disable Jumper.....	95
E25-28: Select Encoder Index input or AENA output (channels 1-4).....	96
E35-39: Select Encoder Index input or AENA output (channels 5-8).....	96
E3: Re-Initialization on Reset Control.....	96

INTRODUCTION

The Geo Brick combines the intelligence and capability of the Turbo PMAC2 motion controller with the latest IGBT-based drive technology, resulting in a compact, smart 4-, 6- or 8-axis servo drive package. The flexibility of the Turbo PMAC2 enables the Geo Brick to drive Brush, Brushless or AC induction motors with unsurpassed pure digital DSP performance. The absence of analog signals – required for typical motion controller/drive interfacing – enables higher gains, better overall performance and tighter integration, while significantly driving down costs and setup time.

The Geo Brick's embedded 32-axis Turbo PMAC2 motion controller is programmable for virtually any kind of motion control application. The unit's PLC programming features allow for complete machine logic control.

The Geo Brick's drive and motion controller are seamlessly integrated. All diagnostic information (amplifier faults, bus voltage, axis currents, phase current, heatsink temperature, etc.) is accessed by the PMAC and available to user-written PMAC programs (due to be released soon).

The Geo Brick is a fully scaleable automation controller, especially for applications requiring only I/O-driven smart servo control where motion is coordinated by a machine controller (such as a PLC). With the ability to store programs locally and execute based on inputs, Ethernet or high-speed USB 2.0-based communication (RS-232 is optional), the Geo Brick is an ideal solution.

The Geo Brick's functionality doesn't stop there. For applications requiring a complete machine controller with PLC functionality, motion control, extensible I/O via Modbus TCP master, an HMI terminal via Modbus TCP slave or even a PC-based HMI package connected via USB 2.0 or Ethernet, the Geo Brick is again the answer.

Geo Brick Features

The Geo Brick is capable of controlling up to eight axes with direct-PWM commands.

- Motorola DSP 56k digital signal processor
- Turbo PMAC2 CPU (for kinematics, open servo, NC applications)
- Fully Configurable via USB2.0 and/or Ethernet TCP/IP (100 Base-T)
- Operation from a PC
- Stand-alone operation
- Linear and circular interpolation
- 256 motion programs capacity
- 64 asynchronous PLC program capability
- Rotating buffer for large programs
- 36-bit position range (± 64 billion counts)
- Adjustable S-curve acceleration and deceleration
- Cubic trajectory calculations, splines
- Set and change parameters in real time
- Torque, Velocity and Position control standard
- Small footprint saves space
- Full rated temperature cooling standard (no need for additional fans)
- 16 inputs (expandable to 32 with option) fully-protected and isolated with separate commons for two banks of eight



Geo Brick Drive

- Eight thermal-fuse protected outputs (expandable to 16 with option) rated for 0.5A @ 24VDC each (Flexible outputs allow for sinking or sourcing of current depending on whether the common emitter or common collector is used.)
 - Primary encoder for each axis with TTL differential/single-ended inputs with A, B quadrature channels and C index channel, 10 MHz cycle rate, and digital Hall-effect inputs
 - Five flags per axis using DB-25: HOME, PLIM, MLIM and USER inputs; EQU compare outputs for first four axes and five more flags per axis if the 6 or 8-axis system is ordered
 - Optional analog inputs and outputs, ± 5 VDC
 - Optional two PWM outputs.
 - Optional Dual Port RAM (Required for NC)
 - Optional Modbus Protocol
 - Optional Sinusoidal encoder feedback*
 - Optional Resolver feedback*
 - Optional EnDat, Hiperface interfaces.*
- *availability expected in the third quarter of 2006

Amplifier Standard Features

- 4-, 6- or 8-channel direct PWM input from controller
- Integral 4-, 6- or 8-axis servo amplifier delivering from 5A cont./10A peak to 15A cont./30A peak per axis (limited to two axes per drive @ 15/30A)
- Four pin locking connector contacts for motor outputs and 3-phase AC input power and earth ground terminations
- Complete protection: over voltage, under voltage, heatsink and IGBT over temperature, short circuit, over current, input phase loss detection, shunt over-current detection
- Two contacts for shunt regulator resistor termination. (Connector type is locking style.)
- Integrated bus power supply including shunt regulator (GAR48 or GAR78 external resistor required)

Amplifier Ratings

- Output Current:
 - 5A Continuous, 10A Peak (two seconds), RMS.
 - 8A Continuous, 16A Peak (two seconds), RMS**
 - 15A Continuous, 30A Peak (two seconds), RMS****availability expected in the first quarter of 2006
- Output Power:
 - 5/10A unit is rated for 1247 watts per axis (based on modulation depth of 60% rms)
 - 8/16A unit is rated for 1995 watts per axis (based on modulation depth of 60% rms)
 - 15/30A unit is rated for 3741 watts per axis (based on modulation depth of 60% rms)
- Input Current:
 - 5/10A 4-axis unit 13 A(rms)/phase (3-phase) @ 240 VAC Input
 - 8/16A 4-axis unit 21 A(rms)/phase (3-phase) @ 240 VAC Input
 - 15/30A 2-axis unit 20 A(rms)/phase (3-phase) @ 240 VAC Input
- Universal AC input 97-265 VAC, or DC operation from 12VDC to 340VDC.

Feedback Devices

Many motors incorporate a position feedback device. Devices are incremental encoders, resolvers, and sine encoder systems. The Geo Brick is set up to accept incremental encoder feedback.

Historically, the choice of a feedback device has been guided largely by cost and robustness factors. Today, feedbacks are relatively constant for the cost and picked by features such as size and feedback data. More feedback data or resolution provides the opportunity to have higher gains in a servo system.

Geo Brick at its 4-axis version can be ordered with two (Opt-01) or four (Opt-02) secondary quadrature encoders. The 8-axis version of the Geo Brick does not have the option for secondary encoders; it comes standard with eight incremental digital encoders and flags for each axis.

Compatible Motors

The Geo Brick product line is capable of interfacing to a wide variety of motors. The Geo Brick can control almost any type of three-phase brushless motor, including DC brushless rotary, AC brushless rotary, induction, and brushless linear motors. Permanent magnet DC brush motors can also be controlled using two of the amplifiers three phases. Motor selection for an application is a science in itself and cannot be covered in this manual. However, some basic considerations and guidelines are offered. Motor manufacturers include a host of parameters to describe their motor.

Some basic equations can help guide an applications engineer to mate a proper drive with a motor. A typical application accelerates a load to a speed, running the speed for a while and then decelerating the load back into position.

Maximum Speed

The motor's maximum rated speed is given. This speed may or may not be achievable in a given system. The speed could be achieved if enough voltage and enough current loop gain are available. Also, consider the motor's feedback adding limitations to achievable speeds. The load attached to the motor also limits the maximum achievable speed. In addition, some manufacturers will provide motor data with their drive controller, which is tweaked to extend the operation range that other controllers may be able to provide. In general, the maximum speed can be determined by input voltage line-to-line divided by K_b (the motor's back EMF constant). It is wise to de-rate this a little for proper servo applications.

Torque

The torque required for the application can be viewed as both instantaneous and average. Typically, the instantaneous or peak torque is calculated as a sum of machining forces or frictional forces plus the forces required to accelerate the load inertia. The machining or frictional forces on a machine must be determined by the actual application. The energy required to accelerate the inertia follows the equation: $T = JA$, where T is the torque in Newton-meters or pound-feet required for the acceleration, J is the inertia in kilogram-meters-squared or pound-feet-second-squared, and A is in radians per second per second. The required torque can be calculated if the desired acceleration rate and the load inertia reflected back to the motor are known. The $T=JA$ equation requires that the motor's inertia be considered as part of the inertia-requiring torque to accelerate.

Once the torque is determined, the motors specification sheet can be reviewed for its torque constant parameter (K_t). The torque required at the application divided by the K_t of the motor provides the peak current required by the amplifier. A little extra room should be given to this parameter to allow for good servo control.

Most applications have a duty cycle in which the acceleration profile occurs repetitively over time. Calculating the average value of this profile gives the continuous rating required by the amplifier. Applications also concern themselves with the ability to achieve a speed. The requirements can be reviewed by either defining what the input voltage is to the drive, or defining what the voltage requirements are at the motor. Typically, a system is designed at a 230 or 480V input line. The motor

must be able to achieve the desired speed with this voltage limitation. This can be determined by using the voltage constant of the motor (K_b), usually specified in volts-per-thousand rpm. The application speed is divided by 1000 and multiplied by the motor's K_b . This is the required voltage to drive the motor to the desired velocity. Headroom of 20% is suggested to allow for good servo control.

Peak Torque

The peak torque rating of a motor is the maximum achievable output torque. It requires that the amplifier driving it be able to output enough current to achieve this. Many drive systems offer a 3:1 peak-to-continuous rating on the motor, while the amplifier has a 2:1 rating. To achieve the peak torque, the drive must be sized to be able to deliver the current to the motor. The required current is often stated on the datasheet as the peak current through the motor. In some sense, it can also be determined by dividing the peak amplifier's output rating by the motor's torque constant (K_t).

Continuous Torque

The continuous torque rating of the motor is defined by a thermal limit. If more torque is consumed from the motor than this on average, the motor overheats. Again, the continuous torque output of the motor is subject to the drive amplifier's ability to deliver that current. The current is determined by the manufacturer's datasheets stating the continuous RMS current rating of the motor and can also be determined by using the motor's K_t parameter, usually specified in torque output per amp of input current.

Motor Poles

Usually, the number of poles in the motor is not a concern to the actual application. However, it should be noted that each pole-pair of the motor requires an electrical cycle. High-speed motors with high motor pole counts can require high fundamental drive frequencies that a drive amplifier may or may not be able to output. In general, drive manufacturers with PWM switching frequencies (16kHz or below) would like to see commutation frequencies less than 400 Hz. The commutation frequency is directly related to the number of poles in the motor.

Motor Inductance

PWM outputs require significant motor inductance to turn the on-off voltage signals into relatively smooth current flow with small ripple. Typically, motor inductance of servomotors is 1 to 15 mH. The Geo drive product series can drive this range easily. On lower-inductance motors (below 1mH), problems occur due to PWM switching where large ripple currents flow through the motor, causing excessive energy waste and heating. If an application requires a motor of less than 1mH, external inductors are recommended to increase that inductance. Motors with inductance in excess of 15mH can still be driven, but are slow to react and typically are out of the range of high performance servomotors.

Motor Resistance

Motor resistance is not really a factor in determining the drive performance, but rather, comes into play more with the achievable torque or output horsepower from the motor. The basic resistance shows up in the manufacturer's motor horsepower curve.

Motor Back EMF

The back EMF of the motor is the voltage that it generates as it rotates. This voltage subtracts from the bus voltage of the drive and reduces the ability to push current through the motor. Typical back EMF ratings for servomotors are in the area of 8 to 200 volts-per-thousand rpm. The Geo drive product series can drive any range of back EMF motor, but the back EMF is highly related to the other parameters of the motor such as the motor inductance and the motor K_t . It is the back EMF of the motor that limits the maximum achievable speed and the maximum horsepower capability of the motor.

Motor Torque Constant

Motor torque constant is referred to as K_t and usually it is specified in torque-per-amp. It is this number that is most important for motor sizing. When the load that the motor will see and the motor's torque

constant is known, the drive amplifier requirements can be calculated to effectively size a drive amplifier for a given motor. Some motor designs allow K_t to be non-linear, in which K_t will actually produce less torque per unit of current at higher output speeds. It is wise to de-rate the systems torque producing capability by 20% to allow headroom for servo control.

Motor Inertia

Motor inertia comes into play with motor sizing because torque to accelerate the inertia of the motor is effectively wasted energy. Low inertia motors allow for quicker acceleration. However, consider the reflected inertia from the load back to the motor shaft when choosing the motor's inertia. A high ratio of load-to-motor inertia can limit the achievable gains in an application if there is compliance in the transmission system such as belt-drive systems or rubber-based couplings to the systems. The closer the rotor inertia matches the load's reflected inertia to the motor shaft, the higher the achievable gains will be for a given system. In general, the higher the motor inertia, the more stable the system will be inherently. Mechanical gearing is often placed between the load and the motor simply to reduce the reflected inertia back to the motor shaft.

Motor Cabling

Motor cables are an integral part of a motor drive system. Several factors should be considered when selecting motor cables. First, the PWM frequency of the drive emits electrical noise. Motor cables must have a good-quality shield around them. The motor frame must also have a separate conductor to bring back to the drive amplifier to help quench current flows from the motor due to the PWM switching noise. Both motor drain wire and the cable shield should be tied at both ends to the motor and to the drive amplifier.

Another consideration in selecting motor cables is the conductor-to-conductor capacitance rating of the cable. Small capacitance is desirable. Longer runs of motor cable can add motor capacitance loading to the drive amplifier causing undesired spikes of current. It can also cause couplings of the PWM noise into the earth grounds, causing excessive noise as well. Typical motor cable ratings would be 50 pf per foot maximum cable capacitance.

Another factor in picking motor cables is the actual conductor cross-sectional area. This refers to the conductors ability to carry the required current to and from the motor. When calculating the required cable dimensions, consider agency requirements, safety requirements, maximum temperature that the cable will be exposed to, the continuous current flow through the motor, and the peak current flow through the motor. Typically, it is not suggested that any motor cable be less than 14 AWG.

The motor cable's length must be considered as part of the application. Motor cable length affects the system in two ways. First, additional length results in additional capacitive loading to the drive. The drive's capacitive loading should be kept to no more than 1000 pf. Additionally, the length sets up standing waves in the cable, which can cause excessive voltage at the motor terminals. Typical motor cable length runs of up to 60 meters (200 feet) for 230V systems and 15 meters (50 feet) for 480V systems are acceptable. Exceeding these lengths may put other system requirements in place for either a snubber at the motor end or a series inductor at the drive end. The series inductor at the drive end provides capacitance loading isolation from the drive and slows the rise time of the PWM signal into the cable, resulting in less voltage overshoot at the motor.

SPECIFICATIONS

Part Number

Geo Brick Drive Part Number Definition

G B L 4 - C 0 - 5 0 0 - 0 0 0 0

Number of Amplifier Axes

- 4 : Four Axes (Default)
- 6 : Six Axes
- 8 : Eight Axes

CPU Options - Turbo PMAC 2 Processor

- C0: 80Mhz, 8Kx24 Internal, 256Kx24SRAM, 1MB Flash (Default)
- F3: 240Mhz, 192Kx24 Internal, 1Mx24SRAM, 4MB Flash

Axes 1 to 4 Options

- 5: 5A/10A, with encoders and Flags for every axis (Default)
- 8: 8A/16A, with encoders and Flags for every axis (Continuous / Peak)

Axes 5 to 8 Options

- 4** 00 / **05**: No options, 4-axis system, 12-24V flags (Default) / **5V flags**
- 02 / **07**: Four secondary encoders inputs (total of 8 encoder inputs), 12-24V Flag inputs / **5V flags**
- P2 / **P7**: PWM amplifier Interface for channels 7 and 8 with encoders for axes 5 to 8 (4 secondary encoders), 12-24V Flag inputs / **5V flags**
- 6** F2 / **F7**: 5 and 6 axis, 15A/30A, with encoders for channels 5 to 8 (2 secondary encoders), 12-24V Flag inputs / **5V flags**
- W2 / **W7**: 5 and 6 axis, 15A/30A, plus PWM amplifier Interface for channels 7 & 8 with 2 secondary encoders on 7 & 8), 12-24V Flag inputs / **5V flags**
- 8** 52 / **57**: 5-8 axis, 5A/10A, with encoder inputs for all axes, 12-24V Flag inputs / **5V flags**
- 82 / **87**: 5-8 axis, 8A/16A, with encoder inputs for all axes, 12-24V Flag inputs / **5V flags**

*If user wants to order 5V flag inputs then he needs to specify it at the Axes 5 to 8 options
For example:
"06" Two secondary encoder inputs (total of 6 encoder inputs), 5V Flag inputs
"W7" Combines Option P6 and F6 (Hi-Power 5 & 6 axes, plus PWM amplifier Interface for channels 7 and 8), 5V Flag inputs*

If the above Number of Amplifier Axes are selected then only the corresponding Axes 5 to 8 Options are available.

Geo Brick Options

CPU Options

- Option C0 – 80MHz Turbo CPU with 8Kx24 internal memory, 256Kx24 SRAM, 1MB flash memory (Default)
- Option F3 – 240MHz Turbo CPU with 192Kx24 internal memory, 1Mx24 SRAM, 4M flash memory

Secondary Encoder Options

- Two secondary encoder inputs, and flags for all 8 channels
- Two additional secondary encoder inputs for a total of four.

Note: For six axis units, only two secondary encoders can be ordered. For the eight axes units, all secondary encoders are used as primary encoders.

Input Output Options

- Additional 16 inputs and 8 outputs, 0.5A @ 24VDC.
- Analog I/O using two DB9 connectors will provide access to two analog inputs and two analog outputs. The analog inputs are 12-bit resolution A/D. The analog outputs are 12-bit filtered PWM. Additionally, two Amp Enable and two Amp Fault inputs are provided.
- Option to increase the analog inputs and outputs from two to four (12-bit).
- Option for Hi-Resolution analog inputs (16-bit). The Analog outputs remain 12-bit filtered PWM.

Communication Options

Note: To use PMAC-NC software, DPRAM is required

- 0: No Options, Default
- D: DPRAM option, size 32K x 16-bit wide (required for NC software)
- M: ModBus Ethernet Communication Protocol (Software) option
- R: RS232 port on 9-pin D-sub Connector
- S: DPRAM and Modbus Options Combined
- E: DPRAM & RS232 Options Combined
- N: RS232 & ModBus Options Combined
- T: Modbus, DPRAM & RS232 Combined

Analog I/O Options

- 00 / 05
01 / 06
02 / 07: 0: No options (Default)
3: Two Analog Inputs (16-bit) & two analog outputs
4: Four Analog Inputs (16-bit) & four analog outputs
- F1 / F6
F2 / F7: 0: No options (Default)
3: Two Analog Inputs (16-bit) & two analog outputs
- P1 / P6
P2 / P7: 0: No options (Default)
7: Two Analog Inputs (16-bit) & two analog outputs
- S2 / S7
S2 / S7
W2 / W7: 0: No Analog Options available, for this configurations

Note: Analog outputs are 12-bit filtered PWM outputs

If the above Axes 5 to 8 options are selected, then only the corresponding Analog I/O options are available

Digital I/O Option

- 0: No Options (Default)
- 1: Expanded digital I/O, additional 16 inputs and 8 outputs
Outputs are rated: 0.5A@12-24VDC

Communication Options

- Option D – small DPRAM 8K x 16-bit wide required for use with NC software
- Option M – Modbus Communication Protocol
- Option R – RS232 port on 9-pin D-sub Connector
- Option S – DPRAM and Modbus Options Combined
- Option E – DPRAM and RS232 Options Combined
- Option N – RS232 and Modbus Options Combined
- Option T – Modbus, DPRAM and RS232 Combined

Environmental Specifications

Description	Unit	Specifications
Operating Temperature	°C	+0 to 45°C. Above 45°C, derate the continuous peak output current by 2.5% per °C above 45°C. Maximum Ambient is 55°C
Rated Storage Temperature	°C	-25 to +70
Humidity	%	10% to 90% non-condensing
Shock		Call Factory
Vibration		Call Factory
Operating Altitude	Feet (Meters)	To 3300 feet (1000 meters). Derate the continuous and peak output current by 1.1% for each 330 feet (100meters) above the 3300 feet
Air Flow Clearances	in (mm)	3" (76.2mm) above and below unit for air flow

Electrical Specifications

4-axis Configuration

Model	GBL4-xx-50x-xxx	GBL4-xx-80x-xxx
Output Continuous Current (rms/axis)	5A	8A
Output Peak Current for 2 seconds (rms/axis)	10A	16A
Rated Input Power (KVA) @ 240VAC	13A (for all axes)	21A (for all axes)
Output Power (Watts per axis) (based on modulation depth of 60% RMS)	1247W/axis	1995W/axis
Total	4988W	7980W
Power Dissipation (Watts)	498W	798W
Recommended PWM Frequency Mean/Max (kHz)	10/12	Not released
AC Input Line Voltage (VAC rms)	97-265 VAC 3 phase	
DC Input Line Voltage (VDC)	12VDC to 340VDC	
Logic Power (VDC, A)	24VDC, 2A	
Continuous Regen Power rating (Watts)	4800W	
Peak Regen Power rating (Watts)	9600W	
Recommended Regen Resistor	GAR 78	

6-axis Configuration

Model	GBL6-xx-5Fx-xxx		GBL6-xx-8Fx-xxx	
	1-4 axis	5-6 axis	1-4 axis	5-6 axis
Output Continuous Current (rms/axis)	5A	15A	8A	15A
Output Peak Current for 2 seconds (rms/axis)	10A	30A	16A	30A
Rated Input Power (KVA) @ 240VAC	33A (for all axes)		41A (for all axes)	
Output Power (Watts per axis) (based on modulation depth of 60% RMS)	1247 W/axis	3741 W/axis	1995 W/axis	3741 W/axis
Total	12470W		15462W	
Power Dissipation (Watts)	1247W		1546W	
Recommended PWM Frequency Mean/Max (kHz)	Not released		Not released	
AC Input Line Voltage (VAC rms)	97-265 VAC 3 phase			
DC Input Line Voltage (VDC)	12VDC to 340VDC			
Logic Power (VDC, A)	24VDC, 3A			
Continuous Regen Power rating (Watts)	6000W			
Peak Regen Power rating(Watts)	12000W			
Recommended Regen Resistor	GAR 48-3			

8-axis Configuration

Model	GBL8-xx-552- xxx		GBL8-xx-882- xxx		GBL8-xx-582- xxx		GBL8-xx-852- xxx	
	1-4 axis	5-8 axis	1-4 axis	5-8 axis	1-4 axis	5-8 axis	1-4 axis	5-8 axis
Output Continuous Current rms/axis)	5A	5A	8A	8A	5A	8A	8A	5A
Output Peak Current for 2 seconds (rms/axis)	10A	10A	16A	16A	10A	16A	16A	10A
Rated Input Power (KVA) @ 240VAC	26A (for all axes)		42A (for all axes)		34A (for all axes)		34A (for all axes)	
Output Power (Watts per axis) (based on modulation depth of 60% RMS)	1247 W/axis		1995 W/axis		1247 W/axis	1995 W/axis	1995 W/axis	1247 W/axis
Total	9976W		15960W		12968W		12968W	
Power Dissipation (Watts)	998W		1596W		1297W		1297W	
Recommended PWM Frequency Mean/Max (kHz)	Not released		Not released		Not released		Not released	
AC Input Line Voltage (VAC rms)	97-265 VAC 3 phase							
DC Input Line Voltage (VDC)	12VDC to 340VDC							
Logic Power (VDC, A)	24VDC, 4A							
Continuous Regen Power (Watts)	4800W							
Peak Regen Power rating (Watts)	9600W							
Recommended Regen Resistor	GAR 48							

Note:

For Single phase AC Input, de-rating applies. Call the factory for more information.

Recommended Fusing and Wire Gauge

Model	Recommended Fuse (FRN/LPN)	Recommended Wire Gauge*
GBL4-xx-50x-xxx	15	12 AWG
GBL4-xx-80x-xxx	25	10 AWG
GBL6-xx-5Fx-xxx	35	8 AWG
GBL6-xx-8Fx-xxx	40	8 AWG
GBL8-xx-552-xxx	25	10 AWG
GBL8-xx-882-xxx	45	8 AWG
GBL8-xx-582-xxx	35	8 AWG
GBL8-xx-852-xxx	35	8 AWG

* See local and national code requirements

Wire Sizes

Geo Drive electronics create a DC bus by rectifying the incoming AC electricity. The current flow into the drive is not sinusoidal but rather a series of narrow, high-peak pulses. Keep the incoming impedance small to not hinder these current pulses. Conductor size, transformer size, and fuse size recommendations may seem larger than expected normally. All ground conductors should be 8AWG minimum using wires constructed of many strands of small gauge wire. This provides the lowest impedance to high-frequency noises.

Package Types

Geo package types provide various power levels (Low/Medium/High) and up to eight axes configurations mainly with three different package types.

- 4-axes Low/Medium power Drive (5A/10A or 8A/16A):**
 GBL4-xx-50x-xxx and GBL4-xx-80x-xxx
 4.5" wide (114 mm), Maximum Power Handling ~8000 watts
 Package Dimensions: 4.5" W x 15.4" H x 7" D (114 mm W x 391 mm H x 178 mm D)
 Weight: 4.4Kgs (9.6lbs)
- 6-axes : 4-axes Low/Medium power plus 2-axes High power Drive (15A/30A):**
 GBL6-xx-5Fx-xx and GBL6-xx-8Fx-xxx
 8" wide (203mm), Maximum Power Handling ~16,000 watts
 Package Dimensions: 8" W x 15.4" H x 7" D (203mm W x 391 mm H x 178 mm D)
 Weight: Call factory
 (Future Release)
- 8-axes Low/Medium power Drive (5A/10A or 8A/16A):**
 GBL8-xx-552-xxx, GBL8-xx-582-xxx, GBL8-xx-852-xxx and GBL8-xx-882-xxx
 8" wide (203 mm), Maximum Power Handling ~16000 watts
 Package Dimensions: 8" W x 15.4" H x 7" D (203 mm W x 391 mm H x 178 mm D)
 Weight: 9.0Kgs (19.9lbs)

Note: All drives include fan and Heatsink, sized appropriately for the drive needs.

RECEIVING AND UNPACKING

Delta Tau products are thoroughly tested at the factory and carefully packaged for shipment. When the Geo Brick Drive is received, there are several things to be done immediately:

1. Observe the condition of the shipping container and report any damage immediately to the commercial carrier that delivered the drive.
2. Remove the control from the shipping container and remove all packing materials. Check all shipping material for connector kits, documentation, diskettes, CD ROM, or other small pieces of equipment. Be aware that some connector kits and other equipment pieces may be quite small and can be accidentally discarded if care is not used when unpacking the equipment. The container and packing materials may be retained for future shipment.
3. Verify that the part number of the drive received is the same as the part number listed on the purchase order.
4. Inspect the drive for external physical damage that may have been sustained during shipment and report any damage immediately to the commercial carrier that delivered the drive.
5. Electronic components in this amplifier are design-hardened to reduce static sensitivity. However, use proper procedures when handling the equipment.
6. If the Geo Brick Drive is to be stored for several weeks before use, be sure that it is stored in a location that conforms to published storage humidity and temperature specifications stated in this manual.

Use of Equipment

The following restrictions will ensure the proper use of the Geo Brick Drive:

- The components built into electrical equipment or machines can be used only as integral components of such equipment.
- The Geo Drives are to be used only on grounded three-phase industrial mains supply networks (TN-system, TT-system with grounded neutral point).
- The Geo Drives must not be operated on power supply networks without a ground or with an asymmetrical ground.
- If the Geo Drives are used in residential areas, or in business or commercial premises, implement additional filter measures.
- The Geo Drives may be operated only in a closed switchgear cabinet, taking into account the ambient conditions defined in the environmental specifications.

Delta Tau guarantees the conformance of the Geo Drives with the standards for industrial areas stated in this manual, only if Delta Tau components (cables, controllers, etc.) are used.

Geo Brick drive is a combination of a Turbo PMAC2 controller and Geo Amplifier. So parallel with this manual the user needs to use the [Turbo Software reference](#) manual and the [Turbo USERS manual](#).

Note:

Always download the latest manual revision from the Delta Tau website:

www.deltatau.com

Note:

If Ethernet communications are used, Delta Tau Systems strongly recommends the use of RJ45 CAT5e or better shielded cable.

Newer network cards have the Auto-MDIX feature that eliminates the need for crossover cabling by performing an internal crossover when a straight cable is detected during the auto-negotiation process.

For older network cards, one end of the link must perform media dependent interface (MDI) crossover (MDIX), so that the transmitter on one end of the data link is connected to the receiver on the other end of the data link (a crossover/patch cable is typically used). If an RJ45 hub is used, then a regular straight cable should be implemented.

Maximum length for Ethernet cable should not exceed 100m (330ft).

MOUNTING

The location of the drive is important. Installation should be in an area that is protected from direct sunlight, corrosives, harmful gases or liquids, dust, metallic particles, and other contaminants. Exposure to these can reduce the operating life and degrade performance of the drive.

Several other factors should be carefully evaluated when selecting a location for installation:

- For effective cooling and maintenance, the control should be mounted on a smooth, non-flammable vertical surface.
- At least 76 mm (3 inches) top and bottom clearance must be provided for air flow. At least 10 mm (0.4 inches) clearance is required between controls (each side).
- Temperature, humidity and Vibration specifications should also be taken in account.

The Geo Drives can be mounted with a traditional 4-hole panel mount, two U shape/notches on the bottom and two pear shaped holes on top. This keeps the heat sink and fan inside the mounting enclosure.

If multiple Geo drives are used, they can be mounted side-by-side, leaving at least a 122 mm clearance between drives. This means a 122 mm center-to-center distance (0.4 inches) with the 4-axis Drives. The 8-axis drive can be mounted side by side at 214 mm center-to-center distance (8.4 inches).

It is extremely important that the airflow is not obstructed by the placement of conduit tracks or other devices in the enclosure.

The drive is mounted to a back panel. The back panel should be unpainted and electrically conductive to allow for reduced electrical noise interference. The back panel should be machined to accept the mounting bolt pattern of the drive. Make sure that all metal chips are cleaned up before the drive is mounted so there is no risk of getting metal chips inside the drive.

The drive is mounted to the back panel with four M4 screws and internal-tooth lock washers. It is important that the teeth break through any anodization on the drive's mounting gears to provide a good electrically conductive path in as many places as possible. Mount the drive on the back panel so there is airflow at both the top and bottom areas of the drive (at least three inches).

Caution:

Units must be installed in an enclosure that meets the environmental IP rating of the end product (ventilation or cooling may be necessary to prevent enclosure ambient from exceeding 45° C [113° F]).

The figures below show the mounting dimensions of the drives.

Note:

For more detail drawings (SolidWorks, eDrawings, DXF) visit our website under the product that you are looking for.

4-axis Low/Medium Power Drive

GBL4-xx-50x-xxx and GBL4-xx-80x-xxx (x stands for the different options that can be ordered)

	Width	Depth	Height	Weight
Mounting Dimensions	114mm / 4.50in.	178mm / 7.00in.	391mm / 15.40in.	4.4Kgs (9.6lbs)

Geo Brick amplifier 4-axis

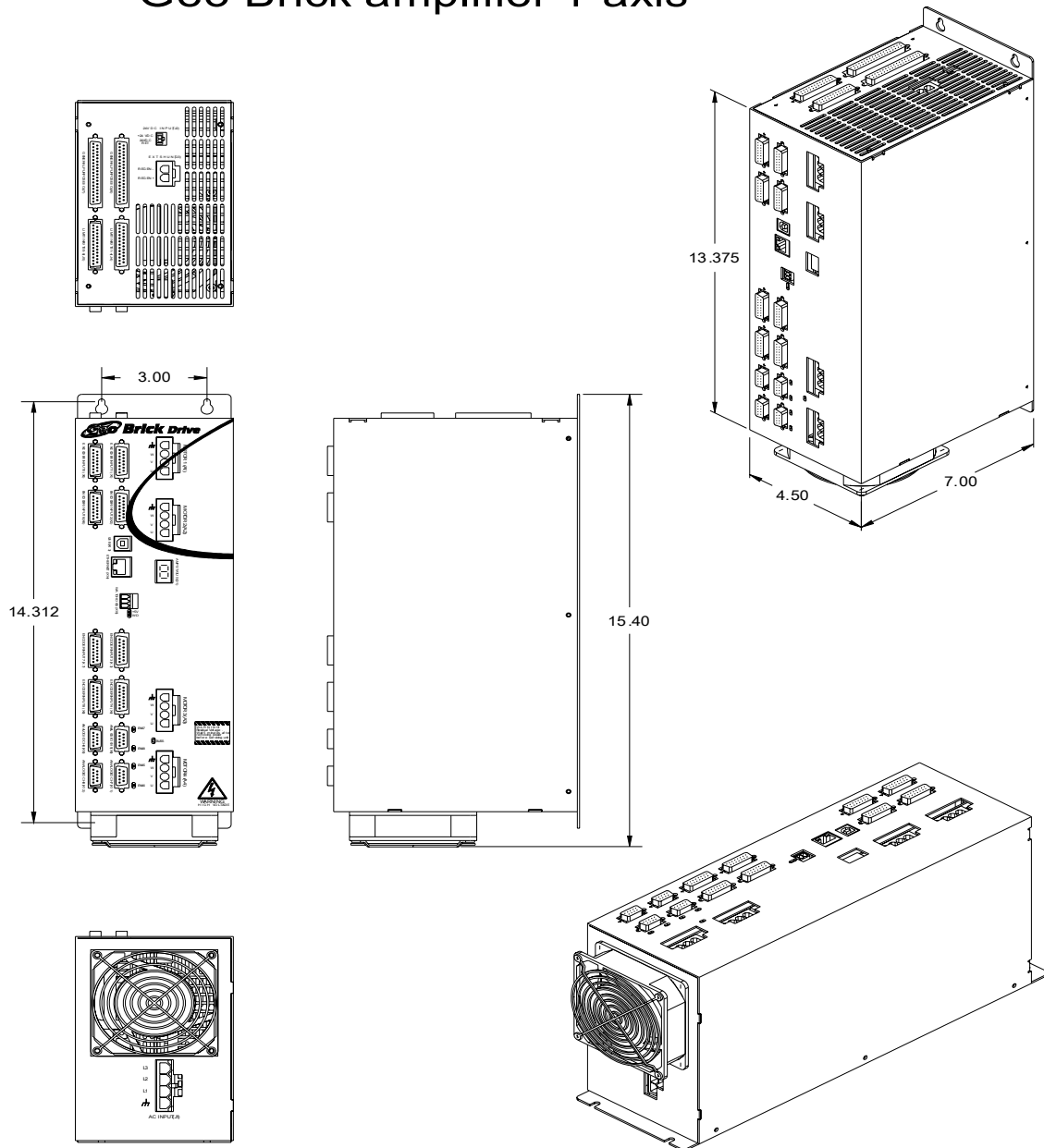

6-axis: 4-axis Low/Medium Power plus 2-axis High Power (15A/30A) Drive

GBL6-xx-5Fx-xxx and GBL6-xx-8Fx-xxx (x stands for the different options that can be ordered)

Mounting Dimensions	Width	Depth	Height	Weight
	203mm / 8.00in.	178mm / 7.00in.	391mm / 15.40in.	Call Factory

Geo Brick Amplifier 6-axis

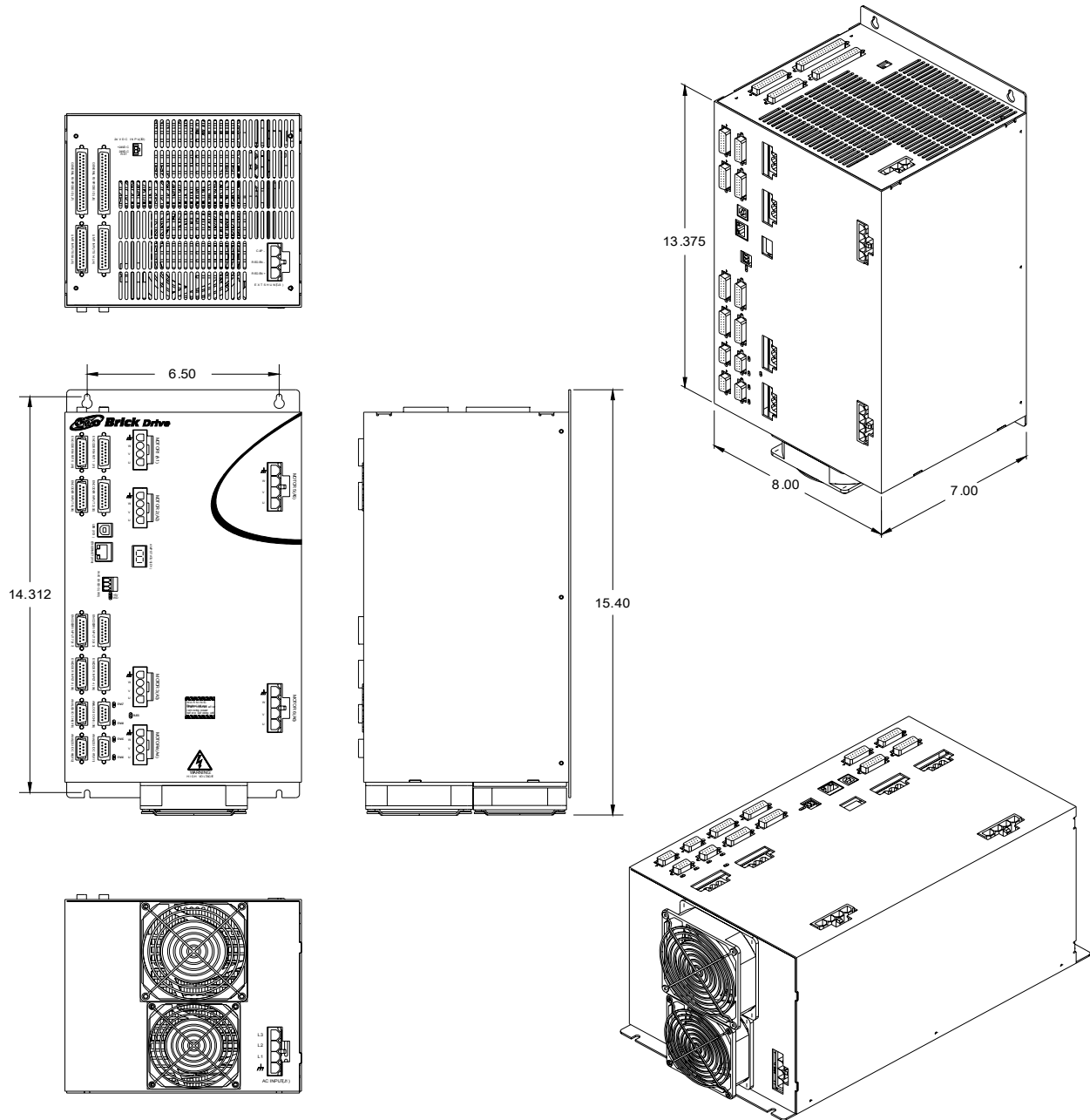

8-axis Low/Medium Power Drive

GBL8-xx-552-xxx, GBL8-xx-582-xxx, GBL8-xx-852-xxx and GBL8-xx-882-xxx (x stands for the different options that can be ordered)

Mounting Dimensions	Width	Depth	Height	Weight
	203mm/ 8.00in.	178mm./ 7.00in.	392mm./ 15.40in.	9.0 kgs (19.9lbs)

Geo Brick Amplifier 8-axis

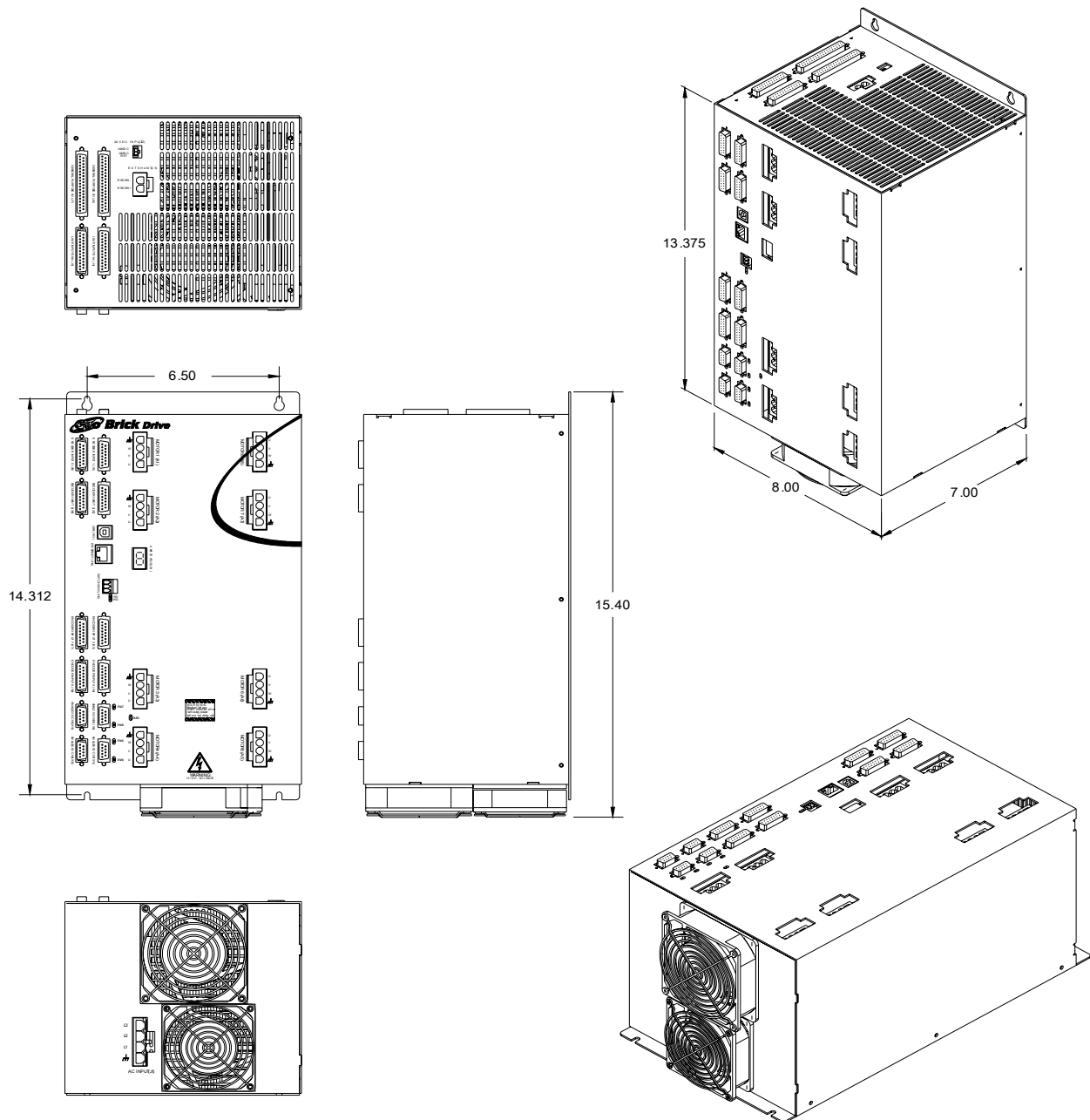

SYSTEM WIRING

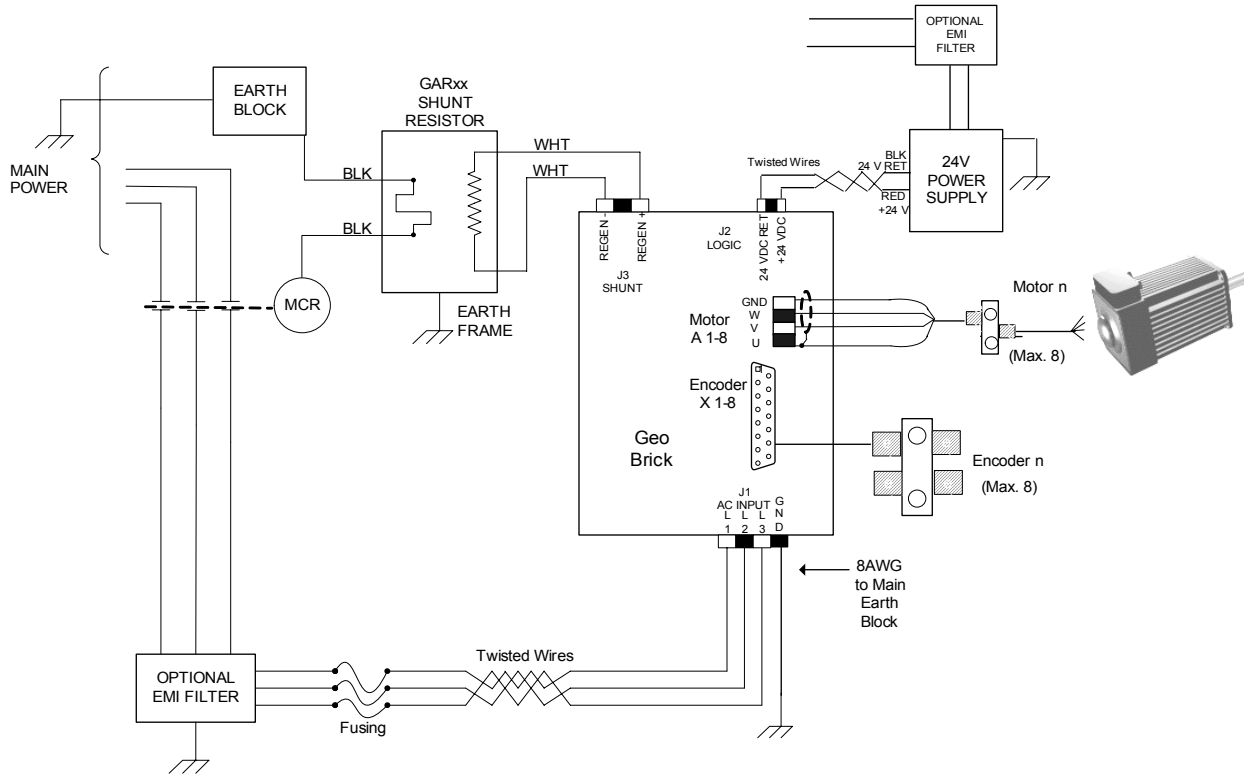

WARNING:

Installation of electrical control equipment is subject to many regulations including national, state, local, and industry guidelines and rules. General recommendations can be stated but it is important that the installation be carried out in accordance with all regulations pertaining to the installation.

Fuse and Circuit Breaker Selection

In general, fusing must be designed to protect the weakest link from fire hazard. Each Geo drive is designed to accept more than the recommended fuse ratings. External wiring to the drive may be the weakest link as the routing is less controlled than the drive's internal electronics. Therefore, external circuit protection, be it fuses or circuit breakers, must be designed to protect the lesser of the drive or external wiring.

High peak currents and high inrush currents demand the use of slow blow type fuses and hamper the use of circuit breakers with magnetic trip mechanisms. Generally, fuses are recommended to be larger than what the rms current ratings require. Remember that some drives allow three times the continuous rated current on up to two axis of motion. Time delay and overload rating of protection devices must consider this operation.

Use of GFI Breakers

Ground Fault Interrupter circuit breakers are designed to break the power circuit in the event that outgoing currents are not accompanied by equal and opposite returning currents. These breakers assume that if outgoing currents are not returning then there is a ground path in the load. Most circuit breakers of this type account for currents as low as 10mA PWM switching in servo drives coupled with parasitic capacitance to ground in motor windings and long cables generate ground leakage current. Careful installation practices must be followed. The use of inductor chokes in the output of the drive will help keep these leakage currents below breaker threshold levels.

Transformer and Filter Sizing

Incoming power design considerations for use with Geo Drives require some over rating. In general, it is recommended that all 3-phase systems using transformers and incoming filter chokes be allotted a 25% over size to keep the impedances of these inserted devices from affecting stated system performance. In general, it is recommended that all single-phase systems up to 1kW be designed for a 50% overload. All single-phase systems over 1kW should be designed for a 200% overload capacity.

Noise Problems

When problems do occur often it points to electrical noise as the source of the problem. When this occurs, turn to controlling high-frequency current paths. If the grounding instructions do not work, insert chokes in the motor phases. These chokes can be as simple as several wraps of the individual motor leads through a ferrite ring core (such as Micrometals T400-26D). This adds high-frequency impedance to the outgoing motor cable thereby making it harder for high-frequency noise to leave the control cabinet area. Care should be taken to be certain that the core's temperature is in a reasonable range after installing such devices.

Operating Temperature

It is important that the ambient operating temperature of the Geo Brick Drive be kept within specifications. The Geo Drive should be installed in an enclosure such as a NEMA cabinet. The internal temperature of the cabinet must be kept under the Geo Drive Ambient Temperature specifications. It is sometimes desirable to roughly calculate the heat generated by the devices in the cabinet to determine if some type of ventilation or air conditioning is required. For these calculations, the Geo Drive's internal heat losses must be known. Budget: 200W per axis for 5A drives, 375W per axis for 8A drives, and 500W per axis for 15A drives. From 0°C to 45°C ambient no de-rating required. Above 45°C, derate the continuous and peak output current by 2.5% per °C above 45°C. Maximum ambient is 55°C.

Single Phase Operation

Due to the nature of power transfer physics, it is not recommended that any system design attempt to consume more than 2kW from any single-phase mains supply. Even this level requires careful considerations. The simple bridge rectifier front end of the Geo Drive, as with all other drives of this type, require high peak currents. Attempting to transfer power from a single-phase system getting one charging pulse each 8.3 milliseconds causes excessively high peak currents that can be limited by power mains impedances. The Geo Drive output voltage sags, the input rectifiers are stressed, and these current pulses cause power quality problems in other equipment connected to the same line. While it is possible to operate drives on single-phase power, the actual power delivered to the motor must be considered. Never design expecting more than 1.5 HP total from any 115V single-phase system and never more than 2.5 HP from any 230V single-phase system.

Wiring AC Input

The main bus voltage supply is brought to the Geo drive through connector J1. It is acceptable to bring the single-phase power into any two of the three input pins (L1/L2/L3) on connector J1. Higher-power drive amplifiers require three-phase input power. It is extremely important to provide fuse protection or overload protection to the input power to the Geo drive amplifier. Typically, this is provided with fuses designed to be slow acting, such as FRN-type fuses. Due to the various regulations of local codes, NEC codes, UL and CE requirements, it is very important to reference these requirements before making a determination of how the input power is wired.

Additionally, many systems require that the power be turned on and off in the cabinet. It is typical that the AC power is run through some kind of main control contact within the cabinet, through the fuses, and then fed to a Geo drive. If multiple Geo drives are used, it is important that each drive has its own separate fuse block.

Whether single- or three-phase, it is important that the AC input wires be twisted together to eliminate noise radiation as much as possible. Additionally, some applications may have further agency noise reduction requirements that require that these lines be fed from an input filtering network.

The AC connections from the fuse block to the Geo drive are made via a cable that is either purchased as an option from Delta Tau (CABKITxx) or made with the appropriate connector kit (CONKITxx). (See Appendix A.)

J1: AC Input Connector Pinout

Pin #	Symbol	Function	Description	Notes
1	GND	Common		
2	L1	Input	Line Input Phase 1	(Not used for single Phase input)
3	L2	Input	Line Input Phase 2	
4	L3	Input	Line Input Phase 3	

If DC bus is used, use L3 for DC+ and L2 for DC return.
 Connector is located at the bottom side of the unit.
 DT Connector part number #014-H00F04-049 and pins part number #014-042815-031
 Molex Crimper tool p/n#63811-1500

Wiring Earth-Ground

Panel wiring requires that a central earth-ground location be installed at one part of the panel. This electrical ground connection allows for each device within the enclosure to have a separate wire brought back to the central wire location. Usually, the ground connection is a copper plate directly bonded to the back panel or a copper strip with multiple screw locations. The Geo Brick drive is brought to the earth-ground via the fourth pin on the J1 connector, located at the bottom of the unit through a heavy gauge, multi-strand conductor to the central earth-ground location. This is done also on the motor output connectors to provide a ground connection.

Earth Grounding Paths

High-frequency noises from the PWM controlled power stage will find a path back to the drive. It is best that the path for the high-frequency noises be controlled by careful installation practices. The major failure in problematic installations is the failure to recognize that wire conductors have impedances at high frequencies. What reads 0 Ohms on a DVM may be hundreds of Ohms at 30MHz. Consider the following during installation planning:

1. Star point all ground connections. Each device wired to earth ground should have its own conductor brought directly back to the central earth ground plate.
2. Use unpainted back panels. This allows a wide area of contact for all metallic surfaces reducing high frequency impedances.

3. Conductors made up of many strands of fine conductors outperform solid or conductors with few strands at high frequencies.
4. Motor cable shields should be bounded to the back panel using 360-degree clamps at the point they enter or exit the panel.
5. Motor shields are best grounded at both ends of the cable. Again, connectors using 360-degree shield clamps are superior to connector designs transporting the shield through a single pin. Always use metal shells.
6. Running motor armature cables with any other cable in a tray or conduit should be avoided. These cables can radiate high frequency noise and couple into other circuits.

Wiring 24 V Logic Control

An external 24Vdc power supply is required to power the logic portion of the Geo Brick drive. This power can remain on, regardless of the main AC input power, allowing the signal electronics to be active while the main motor power control is inactive. The 24V is wired into connector J2. The polarity of this connection is extremely important. Carefully follow the instructions in the wiring diagram. This connection can be made using 22 AWG wire directly from a protected power supply. In situations where the power supply is shared with other devices, it may be desirable to insert a filter in this connection.

The power supply providing this 24V must be capable of providing an instantaneous current of at least 1.8A for the GBL4-, 2.7A for the GBL6-, and 3.8A for the GBL8- models, to be able to start the DC-to-DC converter in the Geo drive. In the case where multiple drives are driven from the same 24V supply, it is recommended that each drive be wired back to the power supply terminals independently. It is also recommended that the power supply be sized to handle the instantaneous inrush current required to start up the DC-to-DC converter in the Geo drive.

J2: 24VDC Input Logic Supply Connector

Pin #	Symbol	Function	Description	Notes
1	24VDC RET	Common	Control power return	Control power return
2	+24VDC	Input	Control power input	24V+/-10%

Connector is located at the top side of the unit
 DT Connector part number #014-043645-200 and pins part number #014-043030-008
 Molex Crimper tool p/n#11-01-0185

Wiring the Motors

The cable wiring must be shielded and have a separate conductor connecting the motor frame back to the drive amplifier. The cables are available in cable kits (CABKITxx) from Delta Tau. (See Appendix A.)

Motor phases are conversed in one of three conventions. Motor manufacturers will call the motor phases A, B, or C. Other motor manufacturers call them U, V, W. Induction motor manufacturers may call them L1, L2, and L3. The drive's inputs are called U, V, and W. Wire U, A, or L1 to the drive's U terminal. Wire V, B, or L2 to the drive's V terminal. Wire W, C, or L3 to the drive's W terminal.

The motor's frame drain wire and the motor cable shield must be tied together and wired at the GND pin of the motor connector (Pin 1).

A1-8: Motor 1 to 8 Output Connector Pinout (Low/Medium Power Units)

Pin #	Symbol	Function	Description	Notes
1	GND	Common		
2	W Phase1	Output	Axis 1 to 8	
3	V Phase2	Output	Axis 1 to 8	
4	U Phase3	Output	Axis 1 to 8	
DT Connector part number #014-00F04-HSG and pins part number #014-043375-001 Molex Crimper tool p/n#63811-0400				

With the High Power option (15A/30A), the unit has total of six axes. The first four axes can be ordered Low/Medium power (5A/10A or 8A/16A) and the other two axes would be High Power (15A/30A). Therefore, the motor connectors for the first four axis (A1-4) are the same with the Low/medium Power Units (see table above), but for axis 5 and 6, larger connectors are used that can handle the extra power (A5 and A6).

A5-6: Motor 5 and 6 High Power Option Connector Pinout

Pin #	Symbol	Function	Description	Notes
1	U Phase3	Output	Axis 5 and 6	
2	V Phase2	Output	Axis 5 and 6	
3	W Phase1	Output	Axis 5 and 6	
4	GND	Common		
DT Connector part number #014-H00F04-049 and pins part number #014-042815-031 Molex Crimper tool p/n#63811-1500				

Regen (Shunt) Resistor Wiring

The Geo Brick Drive family offers compatible regen resistors as optional equipment. The regen resistor is used as a shunt regulator to dump excess power during demanding deceleration profiles. The GAR48 and GAR78 resistors are designed to dump the excess bus energy very quickly.

The regen circuit is also known as a shunt regulator. Its purpose is to dump power fed back into the drive from a motor acting as a generator. Excessive energy can be dumped via an external load resistor. The Geo Brick product series is designed for operation with external shunt resistors of 78 Ω. The 6-axis unit needs 48Ω. Delta Tau has the GAR48 and GAR78 available for these applications. This resistor is provided with pre-terminated cables that plug into connector J3.

Each resistor is the lowest ohm rating for its compatible drive and is limited for use to 200 watts RMS. There are times the regen design might be analyzed to determine if an external Regen resistor is required or what its ratings can be. The following data is provided for such purpose.

Caution:

The black wires are for the thermostat and the white wires are for the regen resistor on the external regen resistor (pictured below). These resistors can reach temperatures of up to 200 degrees C. These resistors must be mounted away from other devices and near the top of the cabinet. Additionally, precautions must be made to ensure the resistors are enclosed and cannot be touched during operation or anytime they are hot. Sufficient warning labels should be placed prominently near these resistors.

The regen resistors incorporate a thermal overload protection thermostat that opens when the core temperature of the resistor exceeds 225 degrees °C. This thermostat is available through the two black leads exiting the resistor. It is important that these two leads be wired in a safety circuit that stops the system from operating should the thermostat open.

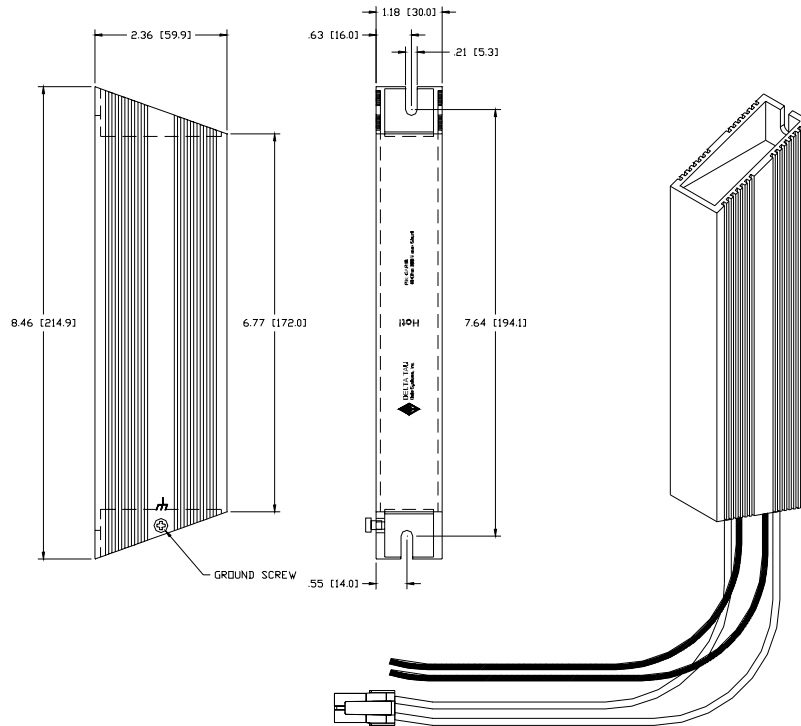

J3: External Shunt Connector Pinout

Pin #	Symbol	Function
1	Regen-	Output
2	Regen+	Output
Connector is located at the top side of the unit DT Connector part number #014-000F02-HSG and pins part number #014-043375-001 Molex Crimper tool p/n#63811-0400		
For the 6-axis Geo Brick, GBL6-xx-xxx-xxx and GBL6-xx-8Fx-xxx, this connector is a 3 pin Large Molex connector		
1	CAP-	Output
2	Regen-	Output
3	Regen+	Output
Connector is located at the top side of the unit. DT Connector part number #014-H00F03-049 and pins part number #014-042815-001. Molex Crimper tool p/n#63811-1500		

Shunt Regulation

When the motor is used to slow the moving load, this is called regenerative deceleration. Under this operation, the motor is acting as a generator consuming energy from the load while passing the energy into the DC Bus storage capacitors. Left unchecked, the DC Bus voltage can raise high enough to damage the drive. For this reason there are protection mechanisms built into the Geo Drive product such as shunt regulation and over-voltage protection.

The shunt regulator monitors the DC Bus voltage. If this voltage rises above a present threshold (Regen Turn On Voltage), the Geo Drive will turn on a power device intended to place the externally mounted regen resistor across the bus to dump the excessive energy. The power device keeps the regen resistor connected across the bus until the bus voltage is sensed to be below the Regen Turn Off voltage, at which time the power device removes the resistor connection.

Minimum Resistance Value

The regen resistor selection requires that the resistance value of the selected resistor will not allow more current to flow through the Geo Drive's power device than specified.

Maximum Resistance Value

The maximum resistor value that will be acceptable in an application is one that will not let the bus voltage reach the drive's stated over voltage specification during the deceleration ramp time. The following equations defining energy transfer can be used to determine the maximum resistance value.

Energy Transfer Equations

Regen, or shunt, regulation analysis requires study of the energy transferred during the deceleration profile. The basic philosophy can be described as follows:

- The motor and load have stored kinetic energy while in motion.
- The drive removes this energy during deceleration by transferring to the DC bus.
- There are losses during this transfer, both mechanical and electrical, which can be significant in some systems.
- The DC bus capacitors can store some energy.
- The remaining energy, if any, is transferred to the regen resistor.

Kinetic Energy

The first step is to ascertain the amount of kinetic energy in the moving system, both the motor rotor and the load it is driving. In metric (SI) units, the kinetic energy of a rotating mass is:

$$E_K = \frac{1}{2} J \omega^2$$

where:

E_K is the kinetic energy in joules, or watt-seconds (J, W-s)

J is the rotary moment of inertia in kilogram-meter² (kg-m²)

ω is the angular velocity of the inertia in radians per second (1/s)

If the values are not in these units, first convert them. For example, if the speed is in revolutions per minute (rpm), multiply this value by $2\pi/60$ to convert to radians per second.

When English mechanical units are used, there are additional conversion factors must be included to get the energy result to come out in joules. For example, if the rotary moment of inertia J is expressed in lb-ft-sec², the following equation should be used:

$$E_K = 0.678 J \omega^2$$

If the rotary moment of inertia J is expressed in lb-in-sec², the following equation should be used:

$$E_K = 0.0565 J \omega^2$$

In standard metric (SI) units, the kinetic energy of a linearly moving mass is:

$$E_K = \frac{1}{2} m v^2$$

where:

E_K is the kinetic energy in joules (J)

m is the mass in kilograms (kg)

v is the linear velocity of the mass in meters/second (m/s)

Here also, to get energy in Joules from English mechanical units, additional conversion factors are required. To calculate the kinetic energy of a mass having a weight of W pounds, the following equation can be used:

$$E_K = 0.678 \frac{W}{g} v^2 = 0.0211Wv^2$$

where:

E_K is the kinetic energy in joules (J)

W is the weight of the moving mass in pounds (lb)

g is the acceleration of gravity (32.2 ft/sec²)

v is the linear velocity of the mass in feet per second (ft/sec)

Energy Lost in Transformation

Some energy will be lost in the transformation from mechanical kinetic energy to electrical energy. The losses will be both mechanical due to friction and electrical due to resistance. In most cases, these losses will comprise a small percentage of the transformed energy and can be safely ignored especially because ignoring losses leads to a conservative design. However, if the losses are significant and the system should not be over-designed, calculate these losses.

In metric (SI) units, the mechanical energy lost due to Coulomb (dry) friction in a constant deceleration to stop of a rotary system can be expressed as:

$$E_{LM} = \frac{1}{2} T_f \omega t_d$$

where:

E_{LM} is the lost energy in joules (J)

T_f is the resistive torque due to Coulomb friction in newton-meters (N-m)

ω is the starting angular velocity of the inertia in radians per second (1/s)

t_d is the deceleration time in seconds (s)

If the frictional torque is expressed in the common English unit of pound-feet (lb-ft), the comparable expression is:

$$E_{LM} = 0.678 T_f \omega t_d$$

In metric (SI) units, the mechanical energy lost due to Coulomb (dry) friction in a constant deceleration to stop of a linear system can be expressed as:

$$E_{LM} = \frac{1}{2} F_f v t_d$$

where:

E_{LM} is the lost energy in joules (J)

F_f is the resistive force due to Coulomb friction in newtons (N)

v is the starting linear velocity in meters/second (m/s)

t_d is the deceleration time in seconds (s)

If the frictional force is expressed in the English unit of pounds (lb) and the velocity in feet per second (ft/sec), the comparable expression is:

$$E_{LM} = 0.678 F_f v t_d$$

The electrical resistive losses in a 3-phase motor in a constant deceleration to stop can be calculated as:

$$E_{LE} = \frac{\sqrt{3}}{2} i_{rms}^2 R_{pp} t_d$$

where:

E_{LE} is the lost energy in joules (J)

i_{rms} is the current required for the deceleration in amperes (A), equal to the required deceleration torque divided by the motor's (rms) torque constant K_T

R_{pp} is the phase-to-phase resistance of the motor, in ohms (Ω)

t_d is the deceleration time in seconds (s)

Capacitive Stored Energy in the Drive

The energy not lost during the transformation is initially stored as additional capacitive energy due to the increased DC bus voltage. The energy storage capability of the drive can be expressed as:

$$E_C = \frac{1}{2}C(V_{regen}^2 - V_{nom}^2)$$

where:

E_C is the additional energy storage capacity in joules (J)

C is the total bus capacitance in Farads

V_{regen} is the DC bus voltage at which the regeneration circuit would have to activate, in volts (V)

V_{nom} is the normal DC bus voltage, in volts (V)

Evaluating the Need for a Regen Resistor

Any starting kinetic energy that is not lost in the transformation and cannot be stored as bus capacitive energy must be dumped by the regeneration circuitry in to the regen (shunt) resistor. The following equation can be used to determine whether this will be required:

$$E_{excess} = E_K - E_{LM} - E_{LE} - E_C$$

If E_{excess} in this equation is greater than 0, a regen resistor will be required.

Regen Resistor Power Capacity

A given regen resistor will have both a peak (instantaneous) and a continuous (average) power dissipation limit. It is therefore necessary to compare the required peak and continuous regen power dissipation requirements against the limits for the resistor.

The peak power dissipation that will occur in the regen resistor in the application will be:

$$P_{peak} = \frac{V_{regen}^2}{R}$$

where:

P_{peak} is peak power dissipation in watts (W)

V_{regen} is the DC bus voltage at which the regeneration circuit activates, in volts (V)

R is the resistance value of the regen resistor, in ohms (Ω)

However, this power dissipation will not be occurring all of the time, and in most applications, only for a small percentage of the time. Usually, the regen will only be active during the final part of a lengthy deceleration, after the DC bus has charged up to the point where it exceeds the regen activation voltage.

The average power dissipation value can be calculated as:

$$P_{avg} = P_{peak} \frac{\%on-time}{100}$$

where:

P_{avg} is average power dissipation in watts (W)

$\%on-time$ is the percentage of time the regen circuit is active

Note:

The Turn-on voltage for the shunt circuitry for all Geo drives is 392V. There is a Hysteresis of 20V, so if the regen turns on @ 392V it will not turn off until it drops to 372V.

Bonding

The proper bonding of shielded cables is imperative for minimizing noise emissions and increasing immunity levels. The bonding effect is to reduce the impedance between the cable shield and the back panel.

Power input wiring does not require shielding (screening) if the power is fed to the enclosure via metal conduit. If metal conduit is not used in the system, shielded cable is required on the power input wires along with proper bonding techniques.

Filtering

CE Filtering

The Geo Drive meets the CE Mark standards stated in the front of this manual. Apply proper bonding and grounding techniques, described earlier in this section, when incorporating EMC noise filtering components to meet this standard.

Noise currents often occur in two ways. The first is conducted emissions passed through ground loops. The quality of the system-grounding scheme inversely determines the noise amplitudes in the lines. These conducted emissions are of a common-mode nature from line-to-neutral (ground). The second is radiated high-frequency emissions that usually are capacitively coupled from line-to-line and are differential in nature.

When mounting the filters, make sure the enclosure has an unpainted metallic surface. This allows more surface area to be in contact with the filter housing and provides a lower impedance path between the housing and the back plane. The back panel should have a high frequency ground strap connection to the enclosure frame and earth ground.

Input Power Filtering

Caution:

To avoid electric shock, do not touch filters for at least ten seconds after removing the power supply.

The Geo Drive electronic system components require EMI filtering in the input power leads to meet the conducted emission requirements for the industrial environment. This filtering blocks conducted-type emissions from exiting onto the power lines and provides a barrier for power line EMI.

Adequately size the system. The type of filter must be based on the voltage and current rating of the system and whether the incoming line is single or three-phase. One input line filter may be used for multi-axis control applications. These filters should be mounted as close to the incoming power as possible so noise is not capacitively coupled into other signal leads and cables. Implement the EMI filter according to the following guidelines:

- Mount the filter as close as possible to incoming cabinet power.
- When mounting the filter to the panel, remove any paint or material covering. Use an unpainted metallic back panel, if possible.
- Filters are provided with a ground connection. All ground connections should be tied to ground.
- Filters can produce high leakage currents; they must be grounded before connecting the supply.
- Do not touch filters for a period of ten seconds after removing the power supply.

Motor Line Filtering

Motor filtering may not be necessary for CE compliance of Geo Drives. However, this additional filtering increases the reliability of the system. Poor non-metallic enclosure surfaces and lengthy, unbonded (or unshielded) motor cables that couple noise line-to-line (differential) are some of the factors that may lead to the necessity of motor lead filtering.

Motor lead noise is either common-mode or differential. The common-mode conducted currents occur between each motor lead and ground (line-to-neutral). Differential radiated currents exist from one motor lead to another (line-to-line). The filtering of the lines feeding the motor provides additional attenuation of noise currents that may enter surrounding cables and equipment I/O ports in close proximity.

Differential mode currents commonly occur with lengthy motor cables. As the cable length increases, so does its capacitance and ability to couple noise from line-to-line. While every final system is different and every application of the product causes a slightly different emission profile, it may become necessary to use differential mode chokes to provide additional noise attenuation to minimize the radiated emissions. The use of a ferrite core placed at the Geo Drive end on each motor lead attenuates differential mode noise and lowers frequency (30 to 60 MHz) broadband emissions to within specifications. Delta Tau recommends a Fair-Rite P/N 263665702 (or equivalent) ferrite core.

Common mode currents occur from noise spikes created by the PWM switching frequency of the Geo Drive. The use of a ferrite or iron-powder core toroid places common mode impedance in the line between the motor and the Geo Drive. The use of a common mode choke on the motor leads may increase signal integrity of encoder outputs and associated I/O signals.

I/O Filtering

I/O filtering may be desired, depending on system installation, application, and integration with other equipment. It may be necessary to place ferrite cores on I/O lines to avoid unwanted signals entering and disturbing the Geo.

Connectors

X1-X8: Encoder Input (1 to 8)

The main encoder input channels for the Geo Brick Drive support only differential quadrature feedback. 5V supply to power the encoder is provided.

- 4-axis drives with no Option 01 or Option 02 have only X1 to X4, for a total of four encoders
 - Option 01 adds two extra S. encoders: X5 and X6, for a total of six encoders
 - Option 02 adds two more S. encoders on top of Option 01: X7 and X8 for a total of eight encoder feedbacks.
- 6-axis drives with no Option 02 have only X1 to X6, for a total of six encoders
Option 02 adds two extra S. encoders: X7 and X8 for a total of eight encoder feedbacks.
- 8-axis drives have a default of eight encoders (X1 to X8) and there are no additional encoder options.

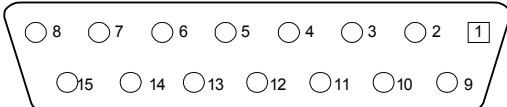
X1-X8 Encoder Input (1-8) (Female DB-15 Connector)			
Pin #	Symbol	Function	Notes
1	CHAN+	Input	Axis n Encoder A+
2	CHBn+	Input	Axis n Encoder B+
3	CHCn+	Input	Axis n Encoder Index+
4	ENCPWRn	Output	Encoder Power 5V
5	CHUn+ / DIRn+	In/Out	Axis n U Commutation+ / If set for Steppers, axis #n Direction output +
6	CHWn+ / PULn+	In/Out	Axis n W Commutation+ / If set for Steppers, axis #n Pulse output +
7	2.5V	Output	2.5V Reference power *
8	Stepper Enable #n	Input	Short pin 8 to pin 4 (5V) to enable stepper output for channel #n*
9	CHAN-	Input	Axis n Encoder A-
10	CHBn-	Input	Axis n Encoder B-
11	CHCn-	Input	Axis n Encoder Index-
12	GND	Common	Common GND
13	CHVn+ / DIRn-	In/Out	Axis n V Commutation+ / If set for Steppers, axis #n Direction output -
14	CHTn+ / PULn-	In/Out	Axis n T Commutation+ / If set for Steppers, axis #n Pulse output -
15	ResOut#n	Output	Resolver excitation output for channel #n *

Because the same pinouts are used for all encoders, n stands for encoder number 1 to 8: n=1 / axis 1, n=2 / axis 2, etc.

*The signals 2.5V / Stepper input enable/ ResOut were implemented to all the Geo Brick Drives that have the Reset button on the front plate. In older versions these signals were not connected.

Note: In the older revisions so as to set it up for Stepper outputs the user had to set internally jumpers.

- Axis 1 to 4 Jumpers E21 to E24
- Axis 5 to 8 Jumpers E31 to E34

For spacing specifications between the DB- connectors, see Appendix A of this manual.

X9-10: Analog I/O Ch5 (X9) and Ch6 (X10), (Optional)

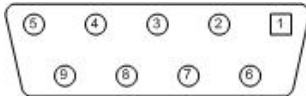
X9/10 (Female DB-9 Connector)			
Pin #	Symbol	Function	Notes
1	AGND		Common
2	ADC5/6+	Input	12-bit Analog Input, channel 5/6+ *
3	DAC5/6+	Output	12-bit filtered PWM analog output, channel 5/6+
4	AE-NC-5/6	Output	Amplifier Enable 5/6 Normally Closed**
5	AMPFLT5/6	Output	Amplifier 5/6 fault output***
6	ADC5/6-	Input	12-bit Analog Input, channel 5/6+ *
7	DAC5/6-	Output	12-bit filtered PWM analog output, channel 5/6+
8	AECOM5/6	Common	Amplifier Enable 5/6 Common
9	AE-NO-5/6	Output	Amplifier Enable 5/6 Normally Open**

*Analog I/O Option 3 replaces the 12-bit ADC inputs (ADS7861EB) with 16-bit ADCs (ADS8321) for both connectors (X9 and X10)
 ** AENA5 - Y:\$78800,8,1 . AENA6 - Y:\$78801,8,1
 *** AMPFLT5: M523-> X:\$078100,15,1 . AMPFLT6: M623-> X:\$078108,15,1
 Note: Earlier revisions of the metal work showed these connectors as being Analog I/O Ch7 (X11) / Analog I/O Ch8 (X12), but it was actually Ch5 and Ch6 at Turbo PMAC addressing.
 For spacing specifications between the DB- connectors, see Appendix A of this manual.

X11-12: Analog I/O Ch7 (X11) and Ch8 (X12), (Optional)

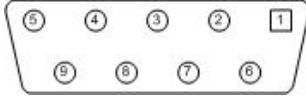
X11/12 (Female DB-9 Connector)			
Pin #	Symbol	Function	Notes
1	AGND		Common
2	ADC7/8+	Input	12-bit Analog Input, channel 7/8+ *
3	DAC7/8+	Output	12-bit filtered PWM analog output, channel 7/8+
4	AE-NC-7/8	Output	Amplifier Enable 7/8 Normally Closed**
5	AMPFLT7/8	Output	Amplifier 7/8 fault output***
6	ADC7/8-	Input	12-bit Analog Input, channel 7/8+ *
7	DAC7/8-	Output	12-bit filtered PWM analog output, channel 7/8+
8	AECOM7/8	Common	Amplifier Enable 7/8 Common
9	AE-NO-7/8	Output	Amplifier Enable 7/8 Normally Open**

*Analog I/O Option 4 replaces the 12-bit ADC inputs (ADS7861EB) with 16-bit ADCs (ADS8321) for both connectors (X11 and X12)
 ** AENA7: M714->Y:\$78803,8,1 . AENA8: M814->Y:\$78804,8,1
 *** AMPFLT7: M523-> X:\$078110,15,1 . AMPFLT8: M623-> X:\$078118,15,1
 Note: Earlier revisions of the metal work showed these connectors as being Analog I/O Ch5 (X9)/ Analog I/O Ch6 (10), but it was actually Ch7 and Ch8 at Turbo PMAC addressing.
 For spacing specifications between the DB- connectors, see Appendix A of this manual.

X13: USB 2.0 Connector

This connector is used in conjunction with USB A-B cable, which can be purchased from any local computer store and is provided when Option 1A is ordered. The A connector is connected to a PC or Hub device; the B connector plugs into the J9-USB port.

Pin #	Symbol	Function
1	VCC	N.C.
2	D-	DATA-
3	D+	DATA+
4	GND	GND
5	SHELL	SHIELD
6	SHELL	SHIELD

X14: RJ45, Ethernet Connector

This connector is used for Ethernet communications from the Geo PMAC Drive to a PC.

Note:

Delta Tau Systems strongly recommends the use of RJ45 CAT5e or better shielded cable.

Newer network cards have the Auto-MDIX feature that eliminates the need for crossover cabling by performing an internal crossover when a straight cable is detected during the auto-negotiation process.

For older network cards, one end of the link must perform media dependent interface (MDI) crossover (MDIX), so that the transmitter on one end of the data link is connected to the receiver on the other end of the data link (a crossover/patch cable is typically used). If an RJ45 hub is used, then a regular straight cable must be implemented.

Maximum length for Ethernet cable should not exceed 100m (330ft).

X15: Watchdog & ABORT

The X15 connector allows the user to send Ohm output from the Geo Brick Drive to the machine if a watchdog condition has occurred at the Drive. This is an important safety feature because the Geo is totally disabled when it is in watchdog condition and this output will allow the other machine's hardware/logic to bring the drive to a safe condition.

Along with the newer versions of the Geo Brick, there is a dedicated ABORT input @24VDC. When the Abort input is asserted, then all enabled motors will be aborted. Motion cannot be resumed until 24V is reapplied to the abort input and the user restarts the program (abort assertion is the absence of 24V).

Notes:

The assertion of the Abort input only affects motors that are enabled at the time the Abort is asserted.

Abort input functionality differs from the Abort command (^A).

There are no software configurable parameters to enable/disable or otherwise manipulate the Abort input functionality.

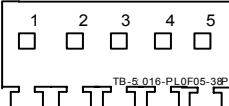
Watchdog (X15) (Phoenix 5-pin Terminal Block)			
Pin #	Symbol	Function	Notes
1	ABORT-	Input	ABORT Reference*
2	ABORT+	Input	ABORT Input signal, 24VDC*
3	N.O.	Output	Normally open contact
4	N.C.	Output	Normally closed contact
5	COM	Input	Watchdog common
<p>*In earlier revision of the Geo Brick X15 used to be only the first three pins, 3 pin Terminal Block. You can recognize the newer version from older if your unit has the reset button and the ABORT input memory addressed @ Y:\$70801,5,1</p> <p>5-pin terminal block connector at the front. 5-pin DT p/n:016-PL0F05-38P Part Type: FRONT-MC 1,5/ 5-ST-3,81 p/n: 1850699 (*3-pin Part Type: FRONT-MC 1, 5/3-ST-3.81 p/n: 1850673)</p>			

RS-232: RS-232 Serial Communication Port

Geo Brick can be ordered with an optional serial RS-232 communication port. This port can be used as a primary means to communicate to the GEO Brick or, because the GEO Brick is based on Turbo PMAC2 architecture, it can also be employed as a secondary port that allows simultaneous communication.

Examples of how it can be utilized for simultaneous communications are, for both a host computer and an operator pendant, or using one port for the applications communications and another for simultaneous monitoring and debugging.

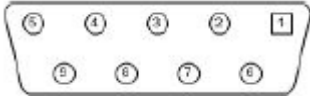
RS-232 (Female DB-9 Connector)				
PIN #	SYMBOL	FUNCTION	DESCRIPTION	NOTES
1	N.C.		NO CONNECT	
2	TXD	OUTPUT	RECEIVE DATA	HOST TRANSMIT DATA
3	RXD	INPUT	SEND DATA	HOST RECEIVE DATA
4	DSR	BIDIRECT	DATA SET RDY	TIED TO "DTR"
5	GND	COMMON	PMAC COMMON	
6	DTR	BIDIRECT	DATA TERM RDY	TIED TO "DSR"
7	CTS	INPUT	CLEAR TO SEND	HOST READY BIT
8	RTS	OUTPUT	REQ. TO SEND	PMAC READY BIT
9	N.C		NO CONNECT	

The baud rate for the RS-232 serial port is set by variable I54. At power-up reset, Turbo PMAC sets the active baud-rate-control register based on the setting of I54 and the CPU speed as set by I52, as the baud rate frequency is divided down from the CPU's operational frequency. The factory default baud rate is 38400. This baud rate will be selected automatically on re-initialization of the Turbo PMAC2, either through use of the re-initialization button or the **\$\$\$***** command. To change the baud rate, change the setting of I54, copy this new setting to non-volatile memory with the **SAVE** command, then reset the Turbo PMAC. Re-establish communications at the new baud rate. The values of I54 and the baud rates they produce are:

I54	Baud Rate	I54	Baud Rate	I54	Baud Rate	I54	Baud Rate
0	600	4	2400	8	9600	12	38,400
1	900	5	3600	9	14,400	13	57,600
2	1200	6	4800	10	19,200	14	76,800
3	1800	7	7200	11	28,800	15	115,200

The baud rate produced by odd-number settings of I54 are only exact if the CPU frequency is an exact multiple of 30 MHz (technically, of 29.4912 MHz). This is because the baud rates are created by dividing the CPU frequency by $(256 * N)$, where N is an integer taken from a lookup table. The frequency is not an exact match for odd settings of I54 and CPU frequencies that are not multiples of 30 MHz. For lower baud rates of this type, the error is not significant. However, serial communications at 115200 baud is possible only if the CPU is running at an exact multiple of 30 MHz (actually an exact multiple of 29.4912 MHz). So to communicate at this rate, run an Option 5Cx 80MHz CPU at 60 MHz, an Option 5Dx 100 MHz CPU at 90 MHz, and an Option 5Ex 160 MHz CPU at 150 MHz by setting I52 to a lower value than the CPU is capable of.

JPWR Power 4-Point Screw Terminal (Internal)

JPWR (Phoenix 4-pin Screw Terminal Connector)			
Pin #	Symbol	Function	Notes
1	GND	Input	Common
2	5V	Input	5V Logic Power, current rating
3	+12V	Input	12Vdc Analog Power, current rating
4	-12V	Input	-12Vdc Analog Power, current rating

This internal connector is used to power up the logic part of the Geo Brick when the amplifier part of the unit is not attached (for Troubleshooting purposes).

Boot SW

This switch is used to reload a new firmware. Power down the unit and power back up while the boot switch is pressed. Released the boot switch after the +5 volt power LED turns on. During the establishing communication, PMAC will appear in bootstrap mode and ask for the new firmware download.

Reset SW

This switch is the hardware re-initialization jumper. If the unit is powered up while pressing the reset switch, PMAC copies the factory default values from the firmware PROM into active memory. This re-initialization procedure is typically only necessary if the unit has been “locked up” due to errant software or parameter settings and communications are impossible to establish.

J4 Limit Inputs (1-4 Axis)

The Geo Brick limit and flag circuits give the flexibility to wire in standard 12V to 24V limits and flags or wire in 5V level limits and flags on a channel basis. The default is set for the standard 12V to 24V inputs, but if the resistor pack is added to the circuit, the card can read 5V inputs.

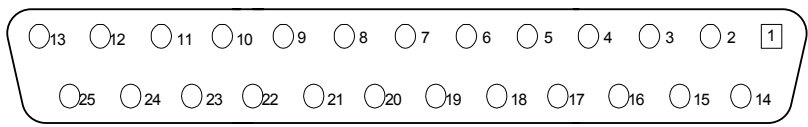
J4 Limit Inputs (Female DB-25 Connector)			
Pin #	Symbol	Function	Description
1	USER1	Input	User Flag 1
2	MLIM1	Input	Negative Limit 1
3	FL_RT1	Input	Flag Return 1
4	USER2	Input	User Flag 2
5	MLIM2	Input	Negative Limit 2
6	FL_RT2	Input	Flag Return 2
7	USER3	Input	User Flag 3
8	MLIM3	Input	Negative Limit 3
9	FL_RT3	Input	Flag Return 3
10	USER4	Input	User Flag 4
11	MLIM4	Input	Negative Limit 4
12	FL_RT4	Input	Flag Return
13	GND	Common	
14	PLIM1	Input	Positive Limit 1
15	HOME1	Input	Home Flag 1
16	BEQU1	Output	Compare Output, EQU 1, signal is TTL (5V) level
17	PLIM2	Input	Positive Limit 2
18	HOME2	Input	Home Flag 2
19	BEQU2	Output	Compare Output, EQU 2, signal is TTL (5V) level
20	PLIM3	Input	Positive Limit 3
21	HOME3	Input	Home Flag 3
22	BEQU3	Output	Compare Output, EQU 3, signal is TTL (5V) level
23	PLIM4	Input	Positive Limit 4
24	HOME4	Input	Home Flag 4
25	BEQU4	Output	Compare Output, EQU 4, signal is TTL (5V) level

If RP39 (limits 1), RP43 (limits 2), RP47 (limits 3) and RP51 (limits 4) are installed to the unit, the voltage level of the flags can be lowered to 5V. User needs to specify these when ordering the unit.
 RP39, RP43, RP47 and RP51 for 5V flags: 1Kohm Sip, 8-pin, four independent Resistors
 RP39, RP43, RP47 and RP51 for 12-24Vflags: Empty bank (Default)
 See Appendix B for Schematic

J5 Limit Inputs (5-8 Axis)

The Geo Brick limit and flag circuits give the flexibility to wire in standard 12V to 24V limits and flags or wire in 5V level limits and flags on a channel basis. The default is set for the standard 12V to 24V inputs, but if the resistor pack is added to the circuit, the card can read 5V inputs.

Note:

J5 comes only with the 6- and 8-axis configuration drives as well with the Secondary Encoder options.

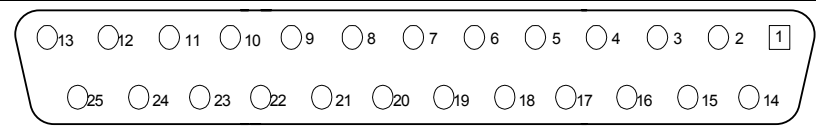
J5 Limit Inputs (Female DB-25 Connector)			
Pin #	Symbol	Function	Description
1	USER5	Input	User Flag 5
2	MLIM5	Input	Negative Limit 5
3	FL_RT5	Input	Flag Return 5
4	USER6	Input	User Flag 6
5	MLIM6	Input	Negative Limit 6
6	FL_RT6	Input	Flag Return 6
7	USER7	Input	User Flag 7
8	MLIM7	Input	Negative Limit 7
9	FL_RT7	Input	Flag Return 7
10	USER8	Input	User Flag 8
11	MLIM8	Input	Negative Limit 8
12	FL_RT8	Input	Flag Return 8
13	GND	Common	
14	PLIM5	Input	Positive Limit 5
15	HOME5	Input	Home Flag 5
16	BEQU5	Output	Compare Output, EQU 5, signal is TTL (5V) level
17	PLIM6	Input	Positive Limit 6
18	HOME6	Input	Home Flag 6
19	BEQU6	Output	Compare Output, EQU 6, signal is TTL (5V) level
20	PLIM7	Input	Positive Limit 7
21	HOME7	Input	Home Flag 7
22	BEQU7	Output	Compare Output, EQU 7, signal is TTL (5V) level
23	PLIM8	Input	Positive Limit 8
24	HOME8	Input	Home Flag 8
25	BEQU8	Output	Compare Output, EQU 8, signal is TTL (5V) level

If J5 is present and RP89 (limits 5), RP93 (limits 6), RP97 (limits 7) and RP101 (limits 8) are installed to the unit, the voltage level of the flags can be lowered to 5V. User needs to specify these when ordering the unit.
 RP89, RP93, RP97 and RP101 for 5V flags: 1Kohm Sip, 8-pin, four independent Resistors
 RP89, RP93, RP97 and RP101 for 12-24V flags: Empty bank. (Default)
 See Appendix B for Schematic

Limit and Flag Circuit Wiring

The Geo Brick allows the use of sinking or sourcing position limits and flags to the controller. The opto-isolator IC used is a PS2705-4NEC-ND quad phototransistor output type. This IC allows the current to flow from return to flag (sinking) or from flag to return (sourcing).

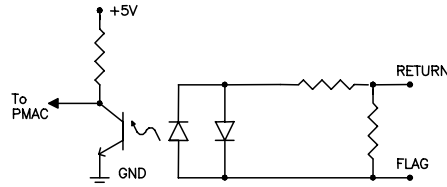

A sample of the positive limit circuit is shown below. The 4.7K resistor packs used will allow 12-24V flag inputs. If 0-5V flags are used, then a 1KΩ resistor pack (RP) can be placed in:

Flags 1-4: RP39 (channel 1), RP43 (channel 2), RP 47 (channel 3), RP51 (channel 4)

Flags 5-8: RP89 (channel 5), RP93 (channel 6), RP 97 (channel 7), and RP 101 (channel 8).

If these resistor packs are not added, all flags (\pm Limits, Home, and User) will be referenced from 12-24V.

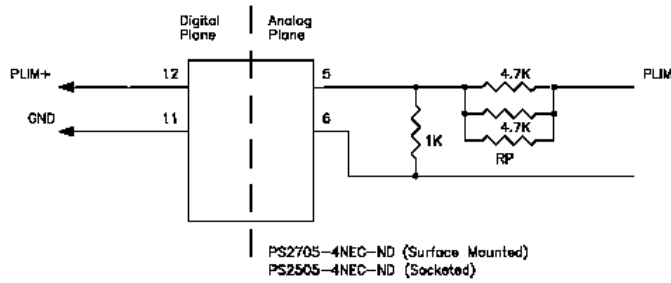

Sample J4/J5, Flags Wiring Diagrams

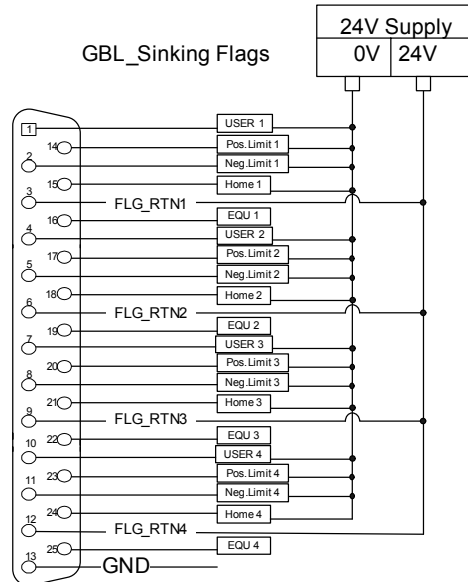
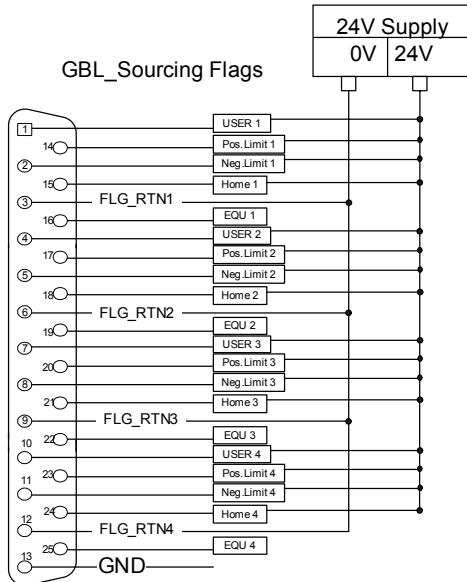
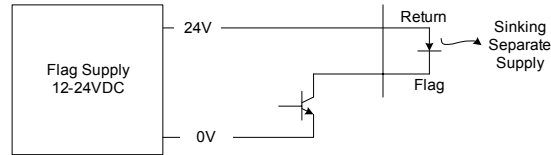
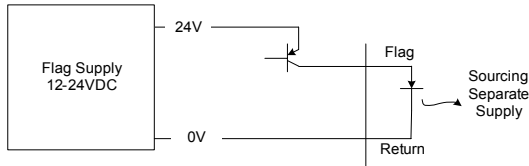

J4 and J5 pinout is the same; J4 is for axis 1-4 and J5 for 5-8.

For the Flags, sinking and sourcing may be mixed depending on the FLG_RTNN input (n=1-8 depending on the channel).

J6: General Purpose I/O

General purpose I/O is available on the Geo Brick Drive. All I/O is electrically isolated from the drive. Inputs can be configured for sinking or sourcing applications. All Inputs are 12-24VDC. All Outputs are 24V nominal operation, 0.5A maximum current. Outputs are robust against ESD and overload.

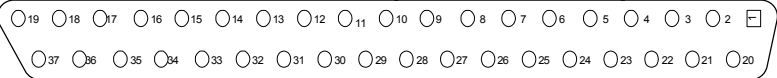
J6 General Purpose I/O (Female DB-37 Connector)			
Pin #	Symbol	Function	Description
1	GPIN01	Input	Input 1
2	GPIN03	Input	Input 3
3	GPIN05	Input	Input 5
4	GPIN07	Input	Input 7
5	GPIN09	Input	Input 9
6	GPIN11	Input	Input 11
7	GPIN13	Input	Input 13
8	GPIN15	Input	Input 15
9	IN_COM 01-08	Input	Input 01 to 08 Common
10	N.C		Not Connected
11	COM_EMT	Input	Common Emitter *
12	GP01-	Output	Sourcing Output 1 **
13	GP02-	Output	Sourcing Output 2 **
14	GP03-	Output	Sourcing Output 3 **
15	GP04-	Output	Sourcing Output 4 **
16	GP05-	Output	Sourcing Output 5 **
17	GP06-	Output	Sourcing Output 6 **
18	GP07-	Output	Sourcing Output 7 **
19	GP08-	Output	Sourcing Output 8 **
20	GPIN02	Input	Input 2
21	GPIN04	Input	Input 4
22	GPIN06	Input	Input 6
23	GPIN08	Input	Input 8
24	GPIN10	Input	Input 10
25	GPIN12	Input	Input 12
26	GPIN14	Input	Input 14
27	GPIN16	Input	Input 16
28	IN_COM 09-16	Input	Input 09 to 16 Common
29	COM_COL	Input	Common Collector **
30	GP01+	Output	Sinking Output 1 *
31	GP02+	Output	Sinking Output 2 *
32	GP03+	Output	Sinking Output 3 *
33	GP04+	Output	Sinking Output 4 *
34	GP05+	Output	Sinking Output 5 *
35	GP06+	Output	Sinking Output 6 *
36	GP07+	Output	Sinking Output 7 *
37	GP08+	Output	Sinking Output 8 *

*For sinking outputs, connect the COM_EMT (pin11) line to the Analog Ground of the Power supply and the outputs to the individual plus output lines, e.g. GPO1+

**For sourcing outputs, connect the COM_COL (pin29) line to 12-24V and the outputs to the individual minus output lines, e.g., GPO1-

Do not mix topologies, i.e., all sinking or all sourcing outputs. If the common emitter is used, the common collector should be unconnected. Conversely, if the common collector is used, the common emitter should be unconnected.

Suggested M-Variable Addressing for the General Purpose I/O (J6)

Suggested M-var. #	Address	Notes		
M0->	Y:\$78800,0,1	Input 1 Data Line, J6 Pin 1		
M1->	Y:\$78800,1,1	Input 2 Data Line, J6 Pin 20		
M2->	Y:\$78800,2,1	Input 3 Data Line, J6 Pin 2		
M3->	Y:\$78800,3,1	Input 4 Data Line, J6 Pin 21		
M4->	Y:\$78800,4,1	Input 5 Data Line, J6 Pin 3		
M5->	Y:\$78800,5,1	Input 6 Data Line, J6 Pin 22		
M6->	Y:\$78800,6,1	Input 7 Data Line, J6 Pin 4		
M7->	Y:\$78800,7,1	Input 8 Data Line, J6 Pin 23		
M8->	Y:\$78801,0,1	Input 9 Data Line, J6 Pin 5		
M9->	Y:\$78801,1,1	Input 10 Data Line, J6 Pin 24		
M10->	Y:\$78801,2,1	Input 11 Data Line, J6 Pin 6		
M11->	Y:\$78801,3,1	Input 12 Data Line, J6 Pin 25		
M12->	Y:\$78801,4,1	Input 13 Data Line, J6 Pin 7		
M13->	Y:\$78801,5,1	Input 14 Data Line, J6 Pin 26		
M14->	Y:\$78801,6,1	Input 15 Data Line, J6 Pin 8		
M15->	Y:\$78801,7,1	Input 16 Data Line, J6 Pin 27		
M32->	Y:\$078802,0,1	Output 1 Data Line	12	30
M33->	Y:\$078802,1,1	Output 1 Data Line	13	31
M34->	Y:\$078802,2,1	Output 1 Data Line	14	32
M35->	Y:\$078802,3,1	Output 1 Data Line	15	33
M36->	Y:\$078802,4,1	Output 1 Data Line	16	34
M37->	Y:\$078802,5,1	Output 1 Data Line	17	35
M38->	Y:\$078802,6,1	Output 1 Data Line	18	36
M39->	Y:\$078802,7,1	Output 1 Data Line	19	37
Do not mix topologies, i.e., all sinking or all sourcing outputs. If the common emitter is used, the common collector should be unconnected. Conversely, if the common collector is used, the common emitter should be unconnected.			Sourcing	Sinking

J7: Extra General Purpose I/O (Optional)

General purpose I/O is available on the Geo Brick Drive. All I/O is electrically isolated from the drive. Inputs can be configured for sinking or sourcing applications. All Inputs are 12-24VDC. All Outputs are 24V nominal operation, 0.5A maximum current. Outputs are robust against ESD and overload.

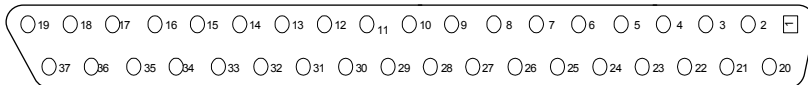
J7 General Purpose I/O (Female DB-37 Connector)			
Pin #	Symbol	Function	Description
1	GPIN17	Input	Input 17
2	GPIN19	Input	Input 19
3	GPIN21	Input	Input 21
4	GPIN23	Input	Input 23
5	GPIN25	Input	Input 25
6	GPIN27	Input	Input 27
7	GPIN29	Input	Input 29
8	GPIN31	Input	Input 31
9	IN_COM 17-24	Input	Input 17 to 24 Common
10	N.C		Not Connected
11	COM_EMT	Input	Common Emitter **
12	GPO9-	Output	Sourcing Output 9 **
13	GPO10-	Output	Sourcing Output 10 **
14	GPO11-	Output	Sourcing Output 11 **
15	GPO12-	Output	Sourcing Output 12 **
16	GPO13-	Output	Sourcing Output 13 **
17	GPO14-	Output	Sourcing Output 14 **
18	GPO15-	Output	Sourcing Output 15 **
19	GPO16-	Output	Sourcing Output 16 **
20	GPIN18	Input	Input 18
21	GPIN20	Input	Input 20
22	GPIN22	Input	Input 22
23	GPIN24	Input	Input 24
24	GPIN26	Input	Input 26
25	GPIN28	Input	Input 28
26	GPIN30	Input	Input 30
27	GPIN32	Input	Input 32
28	IN_COM 25-32	Input	Input 25 to 32 Common
29	COM_COL	Input	Common Collector *
30	GPO9+	Output	Sinking Output 9 *
31	GPO10+	Output	Sinking Output 10 *
32	GPO11+	Output	Sinking Output 11 *
33	GPO12+	Output	Sinking Output 12 *
34	GPO13+	Output	Sinking Output 13 *
35	GPO14+	Output	Sinking Output 14 *
36	GPO15+	Output	Sinking Output 15 *
37	GPO16+	Output	Sinking Output 16 *

*For sinking outputs, connect the COM_EMT (pin11) line to the Analog GND of the Power supply and the outputs to the individual plus output lines, e.g. GPO9+

**For sourcing outputs, connect the COM_COL (pin29) line to 12-24V and the outputs to the individual minus output lines, e.g., GPO9-

Do not mix topologies, i.e., all sinking or all sourcing outputs. If the common emitter is used, the common collector should be unconnected. Conversely, if the common collector is used, the common emitter should be unconnected.

Suggested M-Variable Addressing for the optional General Purpose I/O (J7)

Suggested M-var. #	Address	Notes		
M16->	Y:\$78803,0,1	Input 16 Data Line, J7 Pin 1		
M17->	Y:\$78803,1,1	Input 17 Data Line, J7 Pin 20		
M18->	Y:\$78803,2,1	Input 18 Data Line, J7 Pin 2		
M19->	Y:\$78803,3,1	Input 19 Data Line, J7 Pin 21		
M20->	Y:\$78803,4,1	Input 20 Data Line, J7 Pin 3		
M21->	Y:\$78803,5,1	Input 21 Data Line, J7 Pin 22		
M22->	Y:\$78803,6,1	Input 22 Data Line, J7 Pin 4		
M23->	Y:\$78803,7,1	Input 23 Data Line, J7 Pin 23		
M24->	Y:\$78804,0,1	Input 24 Data Line, J7 Pin 5		
M25->	Y:\$78804,1,1	Input 25 Data Line, J7 Pin 24		
M26->	Y:\$78804,2,1	Input 26 Data Line, J7 Pin 6		
M27->	Y:\$78804,3,1	Input 27 Data Line, J7 Pin 25		
M28->	Y:\$78804,4,1	Input 28 Data Line, J7 Pin 7		
M29->	Y:\$78804,5,1	Input 29 Data Line, J7 Pin 26		
M30->	Y:\$78804,6,1	Input 30 Data Line, J7 Pin 8		
M31->	Y:\$78804,7,1	Input 31 Data Line, J7 Pin 27		
M40->	Y:\$078805,0,1	Output 9 Data Line	12	30
M41->	Y:\$078805,1,1	Output 10 Data Line	13	31
M42->	Y:\$078805,2,1	Output 11 Data Line	14	32
M43->	Y:\$078805,3,1	Output 12 Data Line	15	33
M44->	Y:\$078805,4,1	Output 13 Data Line	16	34
M45->	Y:\$078805,5,1	Output 14 Data Line	17	35
M46->	Y:\$078805,6,1	Output 15 Data Line	18	36
M47->	Y:\$078805,7,1	Output 16 Data Line	19	37
Do not mix topologies, i.e., all sinking or all sourcing outputs. If the common emitter is used, the common collector should be unconnected. Conversely, if the common collector is used, the common emitter should be unconnected.			Sourcing	Sinking

Sample J6/J7, I/O Wiring Diagrams

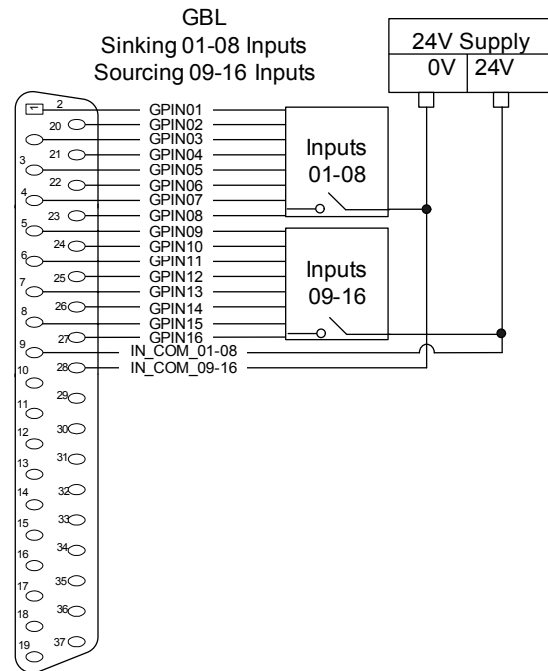
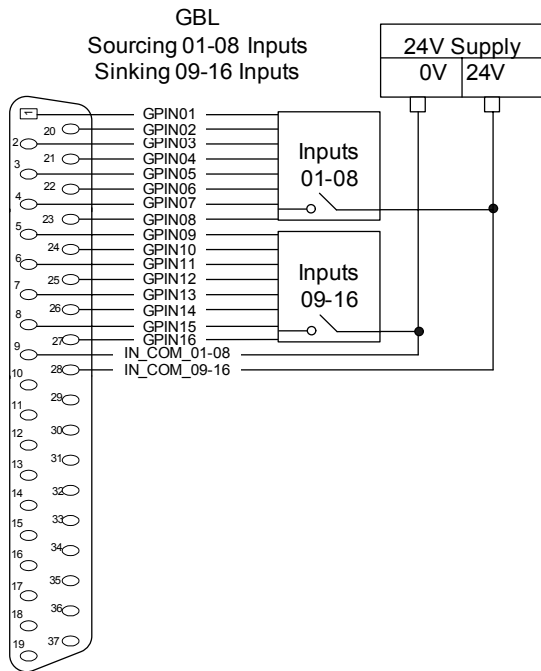
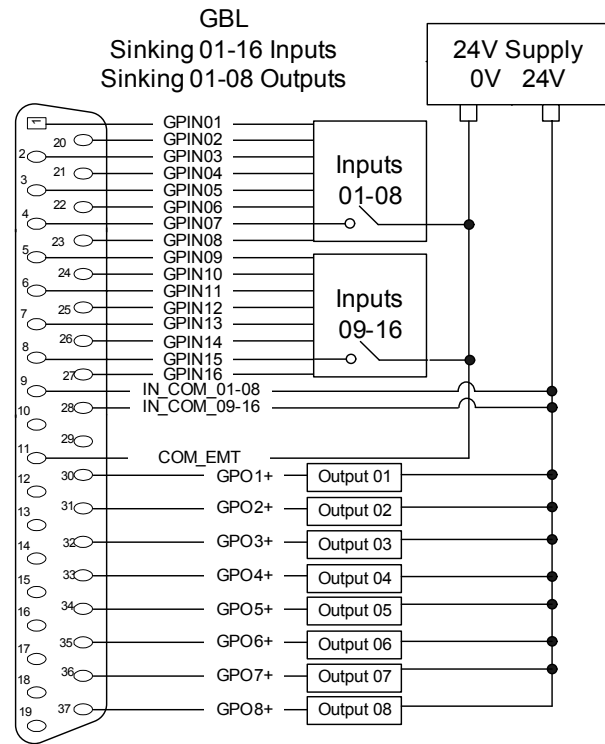
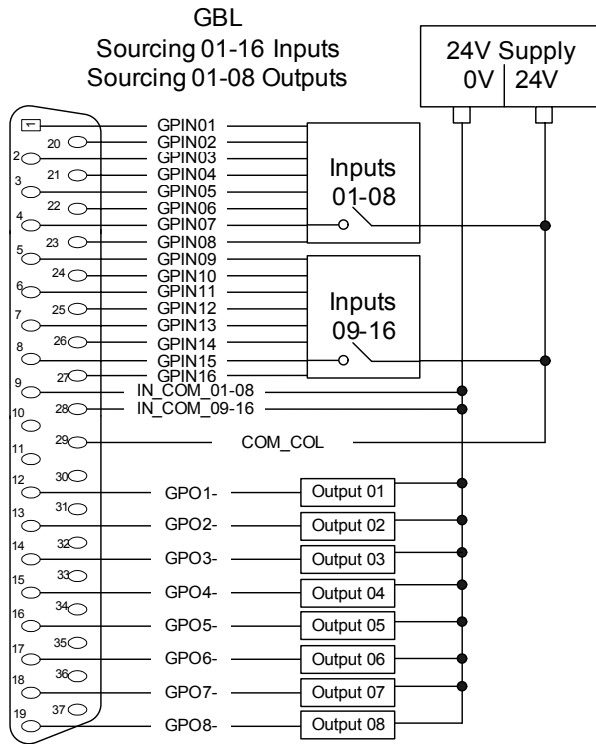

J6 and J7 pinout is the same, J6 is default I/O and J7 (Inputs 17-32 and Outputs 9-16) is installed only when Digital I/O Option is ordered.

Setting up Quadrature Encoders

Digital quadrature encoders are the most common position sensors used with Geo Drives. Interface circuitry for these encoders comes standard on board-level Turbo PMAC controllers, UMAC axis-interface boards, Geo drives, and QMAC control boxes.

Signal Format

Quadrature encoders provide two digital signals that are a function of the position of the encoder, each nominally with 50% duty cycle, and nominally one-quarter cycle apart. This format provides four distinct states per cycle of the signal, or per line of the encoder. The phase difference of the two signals permits the decoding electronics to discern the direction of travel, which would not be possible with a single signal.

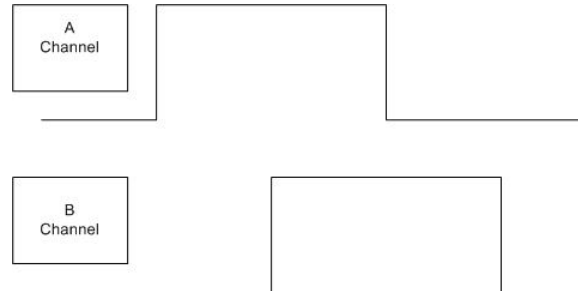

Typically, these signals are at 5V TTL/CMOS levels, whether single-ended or differential. The input circuits are powered by the main 5V supply for the controller, but they can accept up to +/-12V between the signals of each differential pair, and +/-12V between a signal and the GND voltage reference.

Differential encoder signals can enhance noise immunity by providing common-mode noise rejection. Modern design standards virtually mandate their use for industrial systems, especially in the presence of PWM power amplifiers, which generate a great deal of electromagnetic interference.

Hardware Setup

The Geo Drive accepts inputs from up to eight digital encoders and provides encoder position data to the motion processor. X1 is encoder 1 connector and X2 is encoder 2 and respectively up to X8. The differential format provides a means of using twisted pair wiring that allows for better noise immunity when wired into machinery.

Geo Drives encoder interface circuitry employs differential line receivers. The wiring diagram on the right shows an example of how to connect the Geo drive to a quadrature encoder.

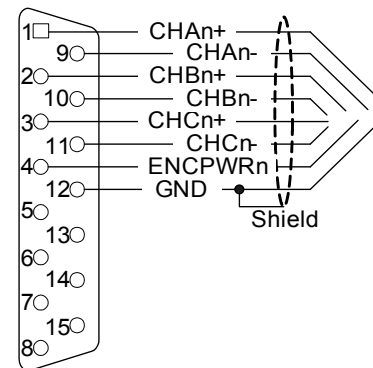

Function	Pin #
CHAn+	1
CHAn-	9
CHBn+	2
CHBn-	10
CHCn+	3
CHCn-	11
ENCPWR	4
GND	12

Encoder Decode	Value	Description
17mn0	3	Clockwise decode
	7	Counter clockwise decode
m = 0 for axis 1-4 (n = 1-4) and m = 1 for axis 5 – 8 (n = 1-4)		

Encoder Loss Setup

Geo Brick controller has encoder-loss detection circuitry for each encoder input. Designed for use with encoders with differential line-driver outputs, the circuitry monitors each input pair with an exclusive-or (XOR) gate. If the encoder is working properly and connected to the Geo Brick, the two inputs of the pair should be in opposite logical states – one high and one low – yielding a true output from the XOR gate.

Note

A single-ended encoder cannot be used on the channel Encoder-Loss Errors

For the Geo Brick Controller Encoder-loss detection bits come in the locations shown in the table below.

Channel#	Address	Description
Encoder #1	Y:\$78807,0,1	Encoder #1 Loss Input Signal
Encoder #2	Y:\$78807,1,1	Encoder #2 Loss Input Signal
Encoder #3	Y:\$78807,2,1	Encoder #3 Loss Input Signal
Encoder #4	Y:\$78807,3,1	Encoder #4 Loss Input Signal
Encoder #5	Y:\$78807,4,1	Encoder #5 Loss Input Signal
Encoder #6	Y:\$78807,5,1	Encoder #6 Loss Input Signal
Encoder #7	Y:\$78807,6,1	Encoder #7 Loss Input Signal
Encoder #8	Y:\$78807,7,1	Encoder #8 Loss Input Signal

As of this writing, there is no automatic action taken on detection of encoder loss. Users who want to take action on detecting encoder loss should write a PLC program to look for a change in the encoder loss bit and take the appropriate action. Generally, the only appropriate response is to kill (open loop, zero output, disabled) the motor with lost encoder feedback; other motors may be killed or aborted as well.

This next example program reacts to a detection of encoder loss. This is a more serious condition than a count error, so a “kill” command is issued when the loss is detected. The example is for a single axis only, but is easy to duplicate for multiple axes.

```

; Substitutions and definitions
#define Mtr1OpenLoop          M138    ; Motor status bit
Mtr1OpenLoop->Y:$0000B0,18,1      ; Standard definition
#define EnclLossIn            M180    ; Input loss-detection bit
EnclLossIn->Y:$078807,0,1        ; Geo Brick Ch1 loss bit
#define Mtr1EncLossStatus     P180    ; Internal latched status
#define Lost                  0       ; Low-true fault here
#define OK                    1       ; High is encoder present
; Program (PLC) to check for and react to encoder loss
OPEN PLC 18 CLEAR
; Logic to disable and set fault status
IF (Mtr1OpenLoop=0 AND EnclLossIn=Lost)    ; Closed loop, no enc
    CMD^K                                  ; Kill all motors
    Mtr1EncLossStatus=1                    ; Indicate encoder loss
ENDIF
; Logic to clear fault status
IF (Mtr1OpenLoop=1 AND EnclLossIn=OK AND Mtr1EncLossStatus=0)
    Mtr1EncLossStatus=0                    ; Indicate valid encoder signal
ENDIF
CLOSE

```

For more details about Encoder Loss look into the Turbo USERS Manual chapter: *Making Your Application Safe*.

Setting Up Digital Hall Sensors

Many motor manufactures now give the consumer the option of placing both Hall effect sensors and quadrature encoders on the end shaft of brushless motors. This will allow the controller to estimate the rotor magnetic field orientation and adjusts the command among the motor phases properly without rotating the motor at power-up. If this is not done properly, the motor or amplifier could be damaged.

Three-phase digital hall-effect position sensors (or their equivalent) are popular for commutation feedback. They can also be used with any PMAC as low-resolution position/velocity sensors. As commutation position sensors, typically, they are just used by PMAC for approximate power-up phase position; ongoing phase position is derived from the same high-resolution encoder that is used for servo feedback. (Many controllers and amplifiers use these hall sensors as their only commutation position feedback, starting and ongoing, but that is a lower-performance technique.)

Many optical encoders have hall tracks. These commutation tracks provide signal outputs equivalent to those of magnetic hall commutation sensors, but use optical means to create the signals.

Note:

These digital hall-effect position sensors should not be confused with analog hall-effect current sensors used in many amplifiers to provide current feedback data for the current loop.

Signal Format

Digital hall sensors provide three digital signals that are a function of the position of the motor, each nominally with 50% duty cycle, and nominally one-third cycle apart. (This format is often called 120° spacing. Geo Brick Drive has no automatic hardware or software features to work with 60° spacing.) This format provides six distinct states per cycle of the signal. Typically, one cycle of the signal set corresponds to one electrical cycle, or pole pair, of the motor. These sensors, then, can provide absolute (if low resolution) information about where the motor is in its commutation cycle, and eliminate the need to do a power-on phasing search operation.

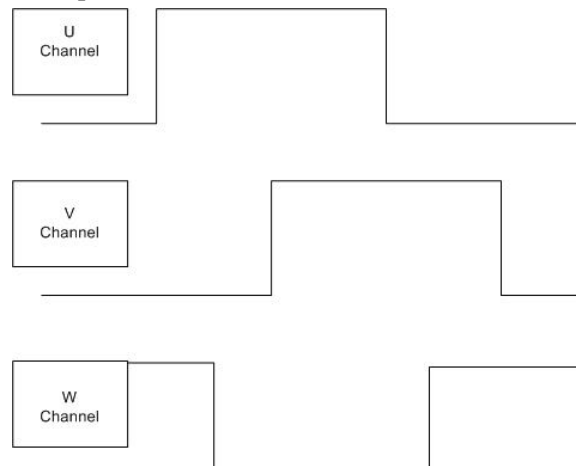

Hardware Setup

If used for power-up commutation position feedback only, typically the hall sensors are wired into the U, V, and W supplemental flags of X1 –X8 connectors of the Geo Brick Drive. These are single-ended 5V digital inputs on all existing hardware implementations. They are not optically isolated inputs; if isolation is desired from the sensor, this must be done externally.

The wiring diagram below shows an example of how to connect the Geo drive with the Hall Sensors.

GBL_Hall effect wiring X1-X8

Function	Pin #
U	5
V	13
W	6
T	14
5V	4
GND	12

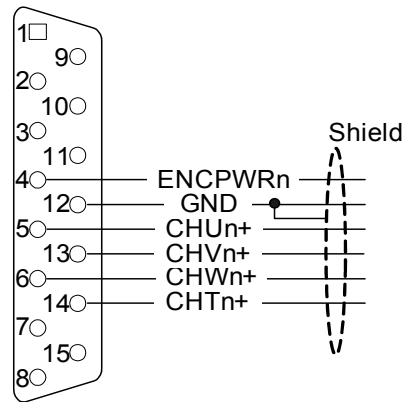

Note:

In the case of magnetic hall sensors, the feedback signals often come back to the controller in the same cable as the motor power leads. In this case, the possibility of a short to motor power must be considered; safety considerations and industrial design codes may make it impermissible to connect the signals directly to the Geo Brick Drive TTL inputs without isolation.

If used for servo position and velocity feedback, the three hall sensors are connected to the A, B, and C encoder inputs, so that the signal edges can be counted. As with quadrature encoders, these inputs can be single-ended or differential. They are not optically isolated inputs; if isolation is desired from the sensor, this must be done externally. There may be applications in which the signals are connected both to U, V, and W inputs (for power-on commutation position) and to A, B, and C inputs (for servo feedback).

Using Hall Effect Sensors for Phase Reference

There are usually four things to be considered about the alignment of the Hall Effect Sensors in order to properly set up Hall Effect phasing within the Geo Drive.

- Commutation Phase angle –based on Ixx72
- Hall Effect Transition Points
- Hall Effect Zero position with respect to PMAC’s electrical zero
- Polarity of the Hall Effects – standard or reversed

Determining the Commutation Phase Angle

The commutation phase angle most likely has been set up already and it can be checked by querying the value of Ixx72. For details on how this is determined, see the Commutation Phase section of the Turbo User Manual, for either Sinusoidal Commutation or Direct PWM Commutation.

	Turbo Ixx72=683	Turbo Ixx72=1365
Commutation Phase Angle	120 degrees	240 degrees

Finding the Hall Effect Transition Points

Usually, hall-effect sensors map out six zones of 60° elec each. In terms of PMAC2’s (non Turbo or Turbo) commutation cycle, usually the boundaries will have one of two different combinations. If the Hall effect sensors are placed at 30°, 150°, and 270°, then the boundaries will be located at 180°, -120°, -60°, 0°, 60°, and 120°. Another common placement of Hall Effect Sensors has them located at 0°, 120°, and 240°. In this case, the boundaries will be located at 30°, 90°, 150°, -150°, -90°, and -30°. Typically, a motor manufacturer will align the sensors to within a few degrees of this, because these are the proper

boundary points if all commutation is done from the commutation sensors. If mounting the hall-effect sensors manually, take care to align the boundaries at these points. The simplest way is to force the motor to the zero degree point with a current offset (as described below) and adjust the sensor while watching its outputs to get a boundary as close as possible to this point.

In order to determine where the Hall effect transition points are located, there must be a method of reading the status in software from the PMAC Executive Software or equivalent setup software. To do this, define M-variables to the Hall-Effects or equivalent inputs. Suggested definitions for Channel 1 are:

Turbo	Description
M124->X:\$078000,20	Channel 1 W flag
M125->X:\$078000,21	Channel 1 V flag
M126->X:\$078000,22	Channel 1 U flag
M127->X:\$078000,23	Channel 1 T flag
M128->X:\$078000,20,4	Channel 1 TUVW as a 4-bit value
M171->X:\$0000B4,0,24,S	Channel 1 Phase Position Register (counts *I170)

Suggested definitions for Channel 2 are:

Turbo	Description
M224->X:\$078008,20	Channel 2 W flag
M225->X:\$078008,21	Channel 2 V flag
M226->X:\$078008,22	Channel 2 U flag
M227->X:\$078008,23	Channel 2 T flag
M228->X:\$078008,20,4	Channel 2 TUVW as a 4-bit value
M271->X:\$000134,0,24,S	Channel 2 Phase Position Register (counts *I270)

Refer to the Turbo PMAC Software Reference manual for the rest of the suggested M-variables.

Create these definitions and add the variables to the Watch window (delete other variables that no longer need to be monitored). With the motor killed, move the motor slowly by hand to verify that the inputs that should change do change.

To map the hall-effect sensors, use the current-loop six-step test, or a variant of it, to force the motor to known positions in the commutation cycle and observe the states of the hall-effect signals.

Calculating the Hall Effect Zero Point (HEZ)

The first step in finding the Hall Effect Zero point is to create a chart of the Hall Sensor Values at different points in the Electrical Cycle. Use the Current Loop 6-step method to do this. Perform the Current Loop 6-step method as described below and record the U (M126), V (M125), and W (M124) values at each step in the procedure.

Current Loop Six-Step Procedure

Commutation Phase Angle at 120° -> Ixx72= 683

Hall Sensors at 30°, 150°, and 270°

```
P179=I179    P129=I129           ; store previous offsets before test
#1o0        ; Open loop command of zero magnitude
```

Six Step Method		U (Mx26)	V(Mx25)	W(Mx24)
I179=3000	I129=-1500 ; -30°elec.			
I179=1500	I129=1500 ; 30°elec.			
I179=-1500	I129=3000 ; 90°elec.			
I179=-3000	I129=1500 ; 150°elec.			
I179=-1500	I129=-1500 ; -150°elec.			
I179=1500	I129=-3000 ; -90°elec.			
I179=3000	I129=-1500; -30°elec.			

```
I179=P179    I129=P129           ; restore previous offsets after test
```

Hall Sensors at 0°, 120°, and 240°

P179=I179 P129=I129 ; store previous offsets before test
 #1o0 ; Open loop command of zero magnitude

Six Step Method	U (Mx26)	V(Mx25)	W(Mx24)
I179=3000 I129=0 ; 0°elec.			
I179=0 I129=3000; 60°elec.			
I179=-3000 I129=3000; 120°elec.			
I179=-3000 I129=0 ; 180°elec.			
I179=0 I129=-3000 ; -120°elec.			
I179=3000 I129=-3000 ; -60°elec.			
I179=3000 I129=0 ; 0°elec.			

I179=P179 I129=P129 ; restore previous offsets after test
 Commutation Phase Angle at 240° -> Ixx72=1365

Hall Sensors at 30°, 150°, and 270°

P179=I179 P129=I129 ; store previous offsets before test
 #1o0 ; Open loop command of zero magnitude

Six Step Method	U (M126)	V(M125)	W(M124)
I179=1500 I129=1500 ; -30°elec.			
I179=3000 I129=-1500 ; 30°elec.			
I179=1500 I129=-3000 ; 90°elec.			
I179=-1500 I129=-1500 ; 150°elec.			
I179=-3000 I129=1500 ; -150°elec.			
I179=-1500 I129=3000 ; -90°elec.			
I179=1500 I129=1500 ; -30°elec.			

I179=P179 I129=P129 ; restore previous offsets after test

Hall Sensors at 0°, 120°, and 240°

P179=I179 P129=I129 ; store previous offsets before test
 #1o0 ; Open loop command of zero magnitude

Six Step Method	U (Mx26)	V(Mx25)	W(Mx24)
I179=3000 I129=0 ; 0°elec.			
I179=3000 I129=-3000 ; 60°elec.			
I179=0 I129=-3000 ; 120°elec.			
I179=-3000 I129=0 ; 180°elec.			
I179=-3000 I129=3000 ; -120°elec.			
I179=0 I129=3000 ; -60°elec.			
I179=3000 I129=0 ; 0°elec.			

I179=P179 I129=P129 ; restore previous offsets after test

Now that the transitions have been mapped out for the sections of the electrical cycle, define and calculate the Hall Effect Zero (HEZ).

Note:

Remember to clear the offsets when finished with this test.

Hall Effect Zero (HEZ) – The Hall Effect Zero is the location in the electrical cycle when U is low (value of 0), W is high (value of 1), and V changes state either from 1 to 0 or from 0 to 1.

Refer to the diagram below as an example:

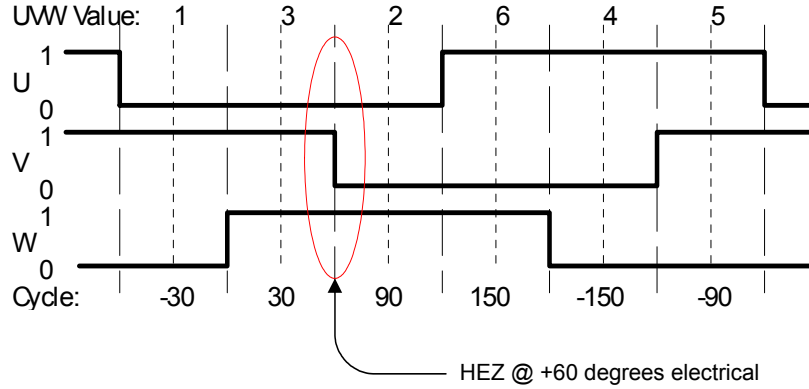

The offset can be computed using the mapping test shown above. In the example, the Hall Effect Zero (HEZ) point was found to be between +30°e and +90°e, so it is called +60°e. The offset value can be computed as:

$$Offset = \frac{HEZ \% 360^\circ}{360^\circ} * 64$$

The offset computed here should be rounded to the nearest integer.

In the example, this comes to:

$$Offset = \frac{+60^\circ \% 360^\circ}{360^\circ} * 64 = \frac{60^\circ}{360^\circ} * 64 = 10.667 \approx 11 = \$0B \text{ hex}$$

Find the Hall Effect Zero and record it for use in setting up Ixx91 (Turbo).

Hall Effect Zero	
-------------------------	--

Determining the Polarity of the Hall Effects – Standard or Reversed

The polarity of the Hall Effects can be determined from the chart recorded in the previous section in the Current Loop 6-step procedure. The polarity depends on how the motor leads were connected with respect to the encoder direction as well as how it was wired in the hall effects with respect to the electrical cycle (in other words the U and V wires were swapped).

Standard Polarity – if the current loop 6-step is being executed in the positive direction of the electrical cycle (from -30 to 30, 90, 150, -150, -90, -30 or 0 to 60, 120, 180, -120, -60,0), the system is considered to have a standard Hall Effect polarity if the transition of V at the Hall Effect Zero is from 0 to 1.

Reversed Polarity - if the current loop 6-step is being executed in the positive direction of the electrical cycle (from -30 to 30, 90, 150, -150, -90, -30 or 0 to 60, 120, 180, -120, -60,0), the system is considered to have a reversed Hall Effect polarity if the transition of V at the Hall Effect Zero is from 1 to 0.

Refer to the chart below as an example:

An easy to determine if the hall effects are standard or reversed (setting bit 22 Ixx91) would be to look at the data in columns.

Ixx79	Ixx29	Electrical Cycle	U	V	W	Positive ↑ The HEZ occurs at 60° electrical. If the transition of V from 0 to 1 at the HEZ point is in the negative direction (like this example), then the hall effect sensing would be considered reversed. If the transition of V from 0 to 1 at the HEZ is in the positive direction, then the hall effect sensing would be considered standard.
3000	-1500	-30	0	1	0	
1500	-3000	-90	1	1	0	
-1500	-1500	-150	1	0	0	
-3000	1500	150	1	0	1	
-1500	3000	90	0	0	1	
1500	1500	30	0	1	1	
3000	-1500	-30	0	1	0	

Record whether the Hall Effects are setup as standard or reversed and move on to the next step of setting up the Controller setup parameters for Hall Effect Power on Phasing.

Software Settings for Hall Effect Phasing

The variables used for Hall Effect Phasing are Ixx81 & Ixx91. These variables are the Power on-phasing setup registers. To enable a Hall Effect Phasing on power up you must configure Ixx81/Ixx91 properly and then enable the power on feature by setting Ixx80=1. The default of Ixx80 is 0 and then a phasing search will only be activated by the \$ command. It is recommended that the phasing search is setup tested with the aid of this document and verified through the \$ command before enabling the power on phasing routine with Ixx80.

Note:

If Ixx73 and Ixx74 have a value greater than zero, then the automatic hall phasing routines will not work. Ixx73 and Ixx74 are used for the automatic step phase method.

Software Setup

Turbo Software Setup

Hall Effect Phasing on Turbo PMACs is setup through Ixx81 and Ixx91. Ixx81 contains address information for the Hall Effect Data and Ixx91 contains the power-on phasing mode as well HEZ and polarity information necessary for Hall Effect Phasing.

Ixx81 Hall Effect Setup for Turbo

Hex (\$)	0				7				8				0				0				0			
Bit	23	22	21	20	19	18	17	16	15	14	13	12	11	10	9	8	7	6	5	4	3	2	1	0
Value	0	0	0	0	0	1	1	1	1	0	0	0	0	0	0	0	0	0	0	0	0	0	0	0

Source Address (\$78000)

The Ixx81 setting contains the location of the Hall Effect Data and is channel dependent. The above setting is channel one on Turbo PMAC2 Geo Brick.

Ixx91 Hall Effect Setup for Turbo

Hex (\$)	C				B				C				0				0				0			
Bit	23	22	21	20	19	18	17	16	15	14	13	12	11	10	9	8	7	6	5	4	3	2	1	0
Value	1	1	0	0	1	0	1	1	0	0	0	0	0	0	0	0	0	0	0	0	0	0	0	0

Hall Effect Offset (\$0B)

Reserved

Standard Hall Sense (0), Reversed Hall Sense (1)

Hall Effect Type Phase (1)

Bit 23

This bit is always set to 1 to tell PMAC to turn on Hall Effect Phasing

Bit 22

Hall Effect Polarity- 0 for **standard** and 1 for **reversed** (see section 6)

Bits 16-21

HEZ in Hexadecimal format, see section 5 above.

Bits 0-15

Reserved

Example:

For a Geo Brick on Axis 1 using Hall Effects with a HEZ of 60°e and reversed polarity the setting would be:

$$Offset = \frac{+60^\circ \% 360^\circ}{360^\circ} * 64 = \frac{60^\circ}{360^\circ} * 64 = 10.667 \approx 11 = \$0B \text{ hex}$$

I181= \$078000

I191= \$800000 + \$400000 + \$0B0000 = \$CB0000

Optimizing the Hall Effect Phasing Routine for Maximum Performance

Since typically there are only three Hall Sensors, the accuracy of phase referencing is good to +/-30° of the commutation cycle, which is enough to get reasonable torque and reasonable smoothness without any phasing search. However, it is recommended to more accurately update the phase position register during the home routine for a particular axis. Since the index pulse is a fixed global reference to the electrical cycle 0 and it is often used in homing routines, the home routine presents a perfect opportunity to optimize the phasing of a motor.

An excellent (and recommended) method of phasing a motor is to use the Halls on power up and then write a value into the phase position register after homing. We have already discussed how to set up the Halls as a power on phasing routine. To execute a fine phasing routine as part of the home routine, follow the procedure below.

Manually Step-phase the Motor

Exercise caution, as a manual step phasing routine will jerk the motor into electrical zero. The distance of the jerk will depend on the number of poles on the motor as well any coupling that may be attached to the motor.

To Manually step phase axis 1 execute the following routine:

```
P179=I179      P129=I129          ;store current offsets
#I00           ;Enable the amplifier
I179=3000      I129=0             ;force motor into Electrical Zero
M171=0         ;zero the phase position register
I179=P179      I129=P129         ;reset current offsets
```

After performing a step-phasing routine the motor will be phased as accurately as possible.

Perform a Home Search Move using the Index Pulse

Execute a home search move using the index pulse or move the motor to the index pulse using an oscilloscope. Once the motor is at index pulse/home routine, record the phase position register value, Mx71, after the motor has settled into position. The value recorded will be the phase position reference whenever it is homed to an index pulse. Store this value in Ixx75. Ixx75 is not used when a Hall Effect automatic phasing routine is enabled. To store this value into flash, make sure to issue a **SAVE** command.

Add Fine Phasing Value as Part of Home Routine

As long as the home routine includes the index pulse as part of the trigger, write the stored value of Ixx75 (from the previous step) to the phase position register after the routine is finished. So on power up the Halls will provide the phasing to enable the motor move through homing routine. After the homing routine is finished, then the phase position register should be updated with a more value than given from the Halls.

Turbo PMAC2 Example:

```
;Homing PLC
open plc11 clear
I7212=3
I7213=0
cmd"#1hm"
while(m140!=0)      ;M140 is in-position bit- suggested m-var
endwhile
M171=I175
close
```

Other Cases

Not all applications will be using the index pulse as part of a homing routine. It is acceptable to use another global fixed position as a fine phasing reference. As long as the position chosen is fixed with respect to the motor's position. Use the same procedure as described above to find the phase position value at that fixed position. First step phase the motor, then move the motor to the desired home routine, let the motor settle, record the phase position and store it into Ixx75. Then after homing, check to make sure the motor is in-position and write the value into Mx71.

This document chose the index pulse to capitalize on the accuracy that PMAC's Gate Array has with respect to latching on the index pulse. Using the index pulse also allows a common value to be stuffed into Mx71 for different machines. Typically, motor manufacturers will mount the index in a repeatable manner with respect to the electrical cycle, although this cannot be guaranteed by Delta Tau. If not homing using the index pulse, then the value for Mx71 must be measured on every machine since it is dependant on the mounting of the motor to a coupling or the location of a home/limit switch.

Example 1:

Geo Brick in Direct PWM Commutation mode with Ixx72=683 and Hall Sensors at 30°, 150°, and 270°

Step	M179	M129	Cycle Pos.	Physical Position	M101 (counts)	M126 (U)	M125 (V)	M124 (W)	M128 (TUVW)
1	+3000	-1500	-30°	3:30	-9001	0	1	0	2
2	+1500	-3000	-90°	2:30	-9343	1	1	0	6
3	-1500	-1500	-150°	1:30	-9673	1	0	0	4
4	-3000	+1500	+150°	12:30	-10030	1	0	1	5
5	-1500	+3000	+90°	11:30	-10375	0	0	1	1
6	+1500	+1500	+30°	10:30	-10709	0	1	1	3
1	+3000	-1500	-30°	9:30	-11050	0	1	0	2

Note:

If the T flag input is 1, the values of Mx28 will be 8 greater than what is shown in the table.

Using the Test Results

To execute a power-on phasing using the hall-effect sensors, use new modes of the Ixx81 power-on phase position parameter, or write a simple PLC program that executes once on power-up/reset.

Setting bit 23 of Ixx81 to 1 specifies a hall-effect power-on phase reference. In this case, the address portion of Ixx81 specifies a PMAC X-address, usually that of the flag register used for the motor, the same address as in Ixx24.

PMAC expects to find the hall-effect inputs at bits 20, 21, and 22 of the specified register. In a flag register, these bits match the CHWn, CHVn, and CHUn inputs, respectively. Hall-effect inputs are traditionally labeled U, V, and W.

The hall-effect signals must each have a duty cycle of 50% (180°e). PMAC can use hall-effect commutation sensors separated by 120°e. There is no industry standard with hall-effect sensors as to direction sense or zero reference, so this must be handled with software settings of Ixx81.

Bit 22 controls the direction sense of the hall-effect sensors as shown in the following diagrams, where a value of 0 for bit 22 is "standard" and a value of 1 is "reversed":

This diagram shows the hall-effect waveforms with zero offset, defined such that the V-signal transition when the U-signal is low (defined as the zero point in the hall-effect cycle) represents the zero point in PMAC’s commutation cycle.

If the hall-effect sensors do not have this orientation, bits 16 to 21 of Ixx81 can be used to specify the offset between PMAC’s zero point and the hall-effect zero point. These bits can take a value of 0 to 63 with units of 1/64 of a commutation cycle (5.625°e). Below is the hall effect waveform diagram constructed from the example.

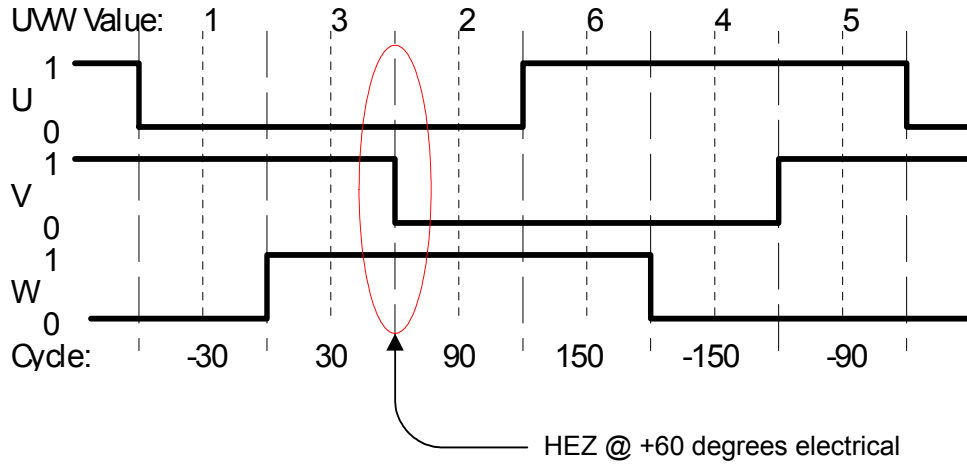

The offset can be computed using the mapping test shown above. In the example, the hall effect zero (HEZ) point was found to be between +30°e and +90°e, so we will call +60°e. The offset value can be computed as:

$$Offset = \frac{HEZ \% 360^{\circ}}{360^{\circ}} * 64$$

The offset computed here should be rounded to the nearest integer.

In the example, this comes to:

$$Offset = \frac{+60^{\circ} \% 360^{\circ}}{360^{\circ}} * 64 = \frac{60^{\circ}}{360^{\circ}} * 64 = 10.667 \approx 11 = \$0B \text{ hex}$$

The test showed that the hall-effect sensors were in the reversed direction, not standard, so bit 22 is set to one. With bit 23 (a value of 8 in the first hex digit) set to 1 to specify hall effect sensing, the first two hex digits of Ix81 become \$CB. If Flag register 1 at address \$C000 were used for the hall-effect inputs, Ix81 would be set to \$CBC000.

An easy method to determine if the hall effects are standard or reversed (setting bit 22) would be to look at the data in columns.

Ixx79	Ixx29	Electrical Cycle	U	V	W
3000	-1500	-30	0	1	0
1500	-3000	-90	1	1	0
-1500	-1500	-150	1	0	0
-3000	1500	150	1	0	1
-1500	3000	90	0	0	1
1500	1500	30	0	1	1
3000	-1500	-30	0	1	0

Positive



The HEZ occurs at 60° electrical. If the transition of V from 0 to 1 at the HEZ point is in the negative direction (like this example), then the hall effect sensing would be considered reversed. If the transition of V from 0 to 1 at the HEZ is in the positive direction, then the hall effect sensing would be considered standard.

The description of Ix81 in the Software Reference shows the common values of offsets used, for all the cases where the zero point in the hall-effect cycle is at a 0°, 60°, 120°, 180°, -120°, or -60° point -- where manufacturers generally align the sensors.

Example:

Turbo PMAC Hall Effect Example with Ixx72=683 Hall Sensors at 30°, 150°, and 270°

For the Turbo PMAC, the Hall effect method of phasing uses two PMAC I-Variables, Ixx81 and Ixx91.

Ixx81 tells PMAC what address to read for absolute power-on phase-position information, if such information is present. Ixx91 tells how the data at the address specified by Ixx81 is to be interpreted.

```
M124->X:$78000,20 ;W channel 1
M125->X:$78000,21 ;V channel 1
M126->X:$78000,22 ;U channel 1
M127->X:$78000,20,4 ;T,U,V,W channel 1
```

Ix79	Ix29	Electrical Cycle	U	V	W
3000	-1500	-30	0	1	0
1500	-3000	-90	1	1	0
-1500	-1500	-150	1	0	0
-3000	1500	150	1	0	1
-1500	3000	90	0	0	1
1500	1500	30	0	1	1
3000	-1500	-30	0	1	0



The HEZ occurs at 60° electrical. If the transition of V from 0 to 1 at the HEZ point is in the negative direction (like this example), then the hall effect sensing would be considered reversed. If the transition of V from 0 to 1 at the HEZ is in the positive direction, then the hall effect sensing would be considered standard. Positive refers to the direction of the electrical cycle

The description of Ixx91 in the Software Reference shows the common values of offsets used, for all the cases where the zero point in the hall-effect cycle is at a 0°, 60°, 120°, 180°, -120°, or -60° point -- where manufacturers generally align the sensors.

Ixx81 Hall Effect phase settings are described in the Turbo Software Reference manual.

Ixx91 Hall Effect Setup for Turbo PMAC2

Hex (\$)	C				B				0				0				0				0			
Bit	23	22	21	20	19	18	17	16	15	14	13	12	11	10	9	8	7	6	5	4	3	2	1	0
Value	1	1	0	0	1	0	1	1	0	0	0	0	0	0	0	0	0	0	0	0	0	0	0	0

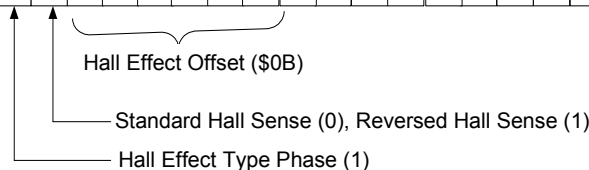

Ixx91 mask = \$80 + \$40 + \$0B = \$CB

For Turbo PMAC2 Geo Brick, axis #1, this would give us I191 = \$CB0000

Setting Up the Analog Inputs (optional)

The Geo Brick Drive can be ordered with up to four analog to digital converters on a 4-Axis Geo Brick Drive and can be ordered with two analog to digital converters on a 6-Axis Geo Brick Drive. There are no analog input options available for an 8-Axis Geo Brick Drive. These A to D converters can be ordered with either the 12-bit low-resolution or 16-bit hi-resolution analog option. These options cannot be mixed; for example, you cannot order 2 low-resolution analog inputs low-resolution and the other two inputs as hi-resolution, nor can you order one low-resolution analog input and one hi-resolution analog input. If four analog inputs are needed, then all four need to be ordered low-resolution or all four hi-resolution. If two analog inputs are needed, both need to be ordered low-resolution or hi-resolution

The Geo Brick uses the Burr Brown ADS7861 for the low-resolution option and ADS8361 for the Hi-resolution option. *See Appendix B for partial Schematics*

When selected for bipolar mode, differential inputs allow the user to apply input voltages to ± 5 volts (10Vp-p).

For a 4-Axis Geo Brick Drive

To read the A/D data, the user needs to set the ADC strobe word for the second gate array to I7106 = \$1FFFFFF for either 12-bit or 16-bit option . Also, the user needs to create M-variable definitions that point to the ADC inputs (M-variables that are used are suggested ones) for channels 5 to 8.

If the **Low-resolution** option (12-bit) is ordered, then the ADC strobe word for channels 5 to 8 (I7106 or X:\$78114) needs to be set equal to **\$1FFFFFF**

Bipolar

The data received is a signed 12-bit number scaled from $-5V$ to $+5V$ (-2047cts to 2048cts).

```
M5061->Y:$78105,12,12,s ;ch5 A-D channel
M5062->Y:$7810D,12,12,s ;ch6 A-D channel
M5063->Y:$78115,12,12,s ;ch7 A-D channel
M5064->Y:$7811D,12,12,s ;ch8 A-D channel
```

If the **High-resolution** option is ordered, then the ADC strobe word for channels 5 to 8 (I7106 or X:\$78114) also needs to be set equal to **\$1FFFFFF**

Bipolar

The data received is a signed 16-bit number scaled from $-5V$ to $+5V$ (-32768cts to 32767cts).

```
M5061->Y:$78105,8,116,s ;ch5 A-D channel
M5062->Y:$7810D,8,16,s ;ch6 A-D channel
M5063->Y:$78115,8,16,s ;ch7 A-D channel
M5064->Y:$7811D,8,16,s ;ch8 A-D channel
```

For a 6-Axis Geo Brick Drive

On a 6-Axis unit, the analog inputs use channels 7 and 8 of the second gate-array and channels 5 and 6 are used for the current loop feedback. The strobe word for the current loop feedback is I7106=\$3FFFFFF, which will set the strobe word for all the channels on the second gate-array. This then creates a conflict in reading the analog ADC inputs because it needs a strobe word value of I7106=\$1FFFFFF for 12-bit option and 16-bit option. Therefore, to satisfy all of the conditions, we can use M-variable definitions and P-variables (M and P-Variables are suggested variables) for calculations that will point to the ADC inputs and setup the strobe word for 12-bit and 16-bit analog option. This can then be put into a PLC program to run in the background.

The **low-resolution** (12-bit) option uses the second gate-array which controls the strobe word for channels 5 to 8 and is set to I7106=\$3FFFFFF for the current loop feedback. We can then create an M-variable (M5000) that will read all the unsigned 24-bits of analog data, which is then copied into a P-variable (P5000). The copied data in P5000 is shifted one bit to the right, which is set to equal to P5001. At the same time the first bit of the 24-bits in P5000 is moved to the front and set as P5003. The results of P5001 and P5003 are added together and then copied into a temporary M-variable location, M5004. The data in M5004 is 24-bits; therefore we can then set M5005 to point to the upper signed 12-bits of M5004, which will be the ADC7 12-bit signed analog input. This can be done by using the PLC program below:

Bipolar

The data received is a signed 12-bit number scaled from -5V to +5V (-2048cts to 2047cts).

```
M5000->y:$78115,0,24,u ;ch7 M-vars for A-D 24-bit raw data.
M5004->x:$10f0,0,24,u ;ch7 Temp M-vars location 24-bits.
M5005->x:$10f0,12,12,s ;ADC7 12-bit analog input (signed).

M6000->y:$7811d,0,24,u ;ch8 M-vars for A-D unsigned 24-bits.
M6004->x:$10f1,0,24,u ;ch8 Temp M-vars location unsigned 24-bits.
M6005->x:$10f1,12,12,s ;ADC8 12-bit analog input.
i5=2 ;Enables background PLCs.

open plc21 clear
P5000=M5000 ;copy values from M5000 to P5000.
P5002=P5000&1 ;mask bit 1 (LSB) of P5000.
P5003=P5002*8388608 ;move bit 1 of P5000 23 bits forward.
P5001=P5000/2 ;move 1 bit to the right of P5000.
M5004=P5001+P5003 ;Assemble M-var unsigned 24-bits to temp
;location by adding P5001 and P5003.

P6000=M6000 ;copy values from M6000 to P6000.
P6002=P6000&1 ;mask bit 1 (LSB) of P6000.
P6003=P6002*8388608 ;move bit 1 of P6000 23 bits forward.
P6001=P6000/2 ;move 1 bit to the right of P6000.
M6004=P6001+P6003 ;Assemble M-var unsigned 24-bits to temp
;location by adding P6001 and P6003.

close
```

After executing this PLC program, the end user can use **M5005** and **M6005** for **ADC7** and **ADC8** respectively to read the 12-bit analog input register.

The **high-resolution** (16-bit) option uses the second gate-array which controls the strobe word for channels 5 to 8 and is set to I7106=\$3FFFFFF for the current loop feedback. We can then create an M-variable (M5000) that will read all the unsigned 24-bits of analog data, which is then copied into a P-variable (P5000). The copied data in P5000 is shifted one bit to the right, which is set to equal to P5001.

At the same time, the first bit of the 24-bits in P5000 is moved to the front and set as P5003. The results of P5001 and P5003 are added together and then copied into a temporary M-variable location, M5004. The data in M5004 is 24-bits; therefore we can then set M5005 to point to the upper signed 16-bits of M5004, which will be the ADC7 16-bit signed analog input. This can be done by using the PLC program constructed below:

Bipolar

The data received is a signed 16-bit number scaled from -5V to +5V (-32768cts to 32767cts).

```

M5000->y:$78115,0,24,u ;ch7 M-vars for A-D 24-bit raw data.
M5004->x:$10f1,0,24,u ;ch7 Temp M-vars location 24-bits.
M5005->x:$10f1,8,16,s ;ADC7 16-bit analog input (signed).

M6000->y:$7811d,0,24,u ;ch8 M-vars for A-D unsigned 24-bits.
M6004->x:$10f1,0,24,u ;ch8 Temp M-vars location unsigned 24-bits.
M6005->x:$10f1,8,16,s ;ADC8 16-bit analog input.
i5=2 ;Enables background PLCs.

open plc21 clear
P5000=M5000 ;copy values from M5000 to P5000.
P5002=P5000&1 ;mask bit 1 (LSB) of P5000.
P5003=P5002*8388608 ;move bit 1 of P5000 23 bits forward.
P5001=P5000/2 ;move 1 bit to the right of P5000.
M5004=P5001+P5003 ;Assemble M-var unsigned 24-bits to temp
;location by adding P5001 and P5003.

P6000=M6000 ;copy values from M6000 to P6000.
P6002=P6000&1 ;mask bit 1 (LSB) of P6000.
P6003=P6002*8388608 ;move bit 1 of P6000 23 bits forward.
P6001=P6000/2 ;move 1 bit to the right of P6000.
M6004=P6001+P6003 ;Assemble M-var unsigned 24-bits to temp
;location by adding P6001 and P6003.

close

```

After executing this PLC program, the end user can use **M5005** and **M6005** for **ADC7** and **ADC8** respectively to read the 16-bit analog input registers.

The Geo Brick analog +/-10V outputs are produced by filtering a PWM signal. This technique has been used for some time now by some other DeltaTau products (PMAC2A-PC/104) and many of our competitors. Although this technique does not contain the same levels of performance as a true Digital to Analog converter (DAC), for most servo applications it is more than adequate. Passing the PWM signal through a 10KHz low pass filter creates the +/-10V signal output. The duty cycle of the PWM signal is what generates the magnitude the voltage output. The frequency of the PWM signal determines the magnitude and frequency of ripple on that +/-10V signal. As you lower the PWM frequency and subsequently increase your output resolution, you increase the magnitude of the ripple as well as slow down the frequency of the ripple as well. Depending on the system, this ripple can effect performance at different levels.

Both the resolution and the frequency of the Filtered PWM outputs are configured in software on the Geo Brick through the variable **I7m00**. This I7m00 variable also effects the phase and servo interrupts. Therefore as we change I7m00 we will also have to change **I7m01** (phase clock divider), **I7m02** (servo clock divider), and **I10** (servo interrupt time). These four variables are all related and must be understood before adjusting parameters. I7mn6 (m=1, n=1-4) needs to be set for PWM output.

When the analog I/O option is ordered the Geo Brick comes with 2 or 4 analog (+/10VDC) output signals. These analog output signals are filtered PWM signals, 12-bit analog outputs. These outputs can be either single-ended or differential. For a single-ended analog output use the DACn+ (pin 3) side of the signal and leave the DACn- (pin 7) floating; do not ground it. For a differential command output, connect the positive side of the DACn+ (pin 3), and the negative side DAC- (pin 7).

To limit the range of each signal to $\pm 5V$, use parameter Ixx69. Any analog output not used for dedicated servo purposes may be utilized as a general-purpose analog output. Usually this is done by defining an M-variable to the digital-to-analog-converter register (suggested M-variable definitions M502, M602, etc.), then writing values to the M-variable. The analog outputs are intended to drive high-impedance inputs with no significant current draw. The 220 Ω output resistors will keep the current draw lower than 50 mA in all cases and prevent damage to the output circuitry, but any current draw above 10 mA can result in noticeable signal distortion.

Example:

Filtered DAC Outputs Configuration

The following I-variables must be set properly to use the digital-to-analog (filtered DAC) outputs:

n = channel number from 5 to 8 and x = motor number from 5 to 8
I7100= 810 ; PWM frequency 30-35kHz, PWM 5-8
I7103 = 2770 ; ADC clock frequency
I7104= 0 ; Zero deadtime
Ixx69= 810 ; DAC limit 10Vdc, anything over I7100 will just
;rail the DAC at 10V

M502->Y:\$78102,8,16,s ;DAC5
M602->Y:\$7810A,8,16,s ;DAC6
M702->Y:\$78112,8,16,s ;DAC7
M802->Y:\$7811A,8,16,s ;DAC8

So as to use M-variables to control the DAC outputs, the Ixx00 need to be set equal to 0

I500=0 ; Axis #5 is not activated
I600=0 ; Axis #6 is not activated
I700=0 ; Axis #7 is not activated
I800=0 ; Axis #8 is not activated

Else the user will have to use Open loop commands or servo at the channels.

Setting up for Pulse and Direction Output

The following section shows how to quickly setup the key variables for a stepper motor (PFM) system.

The step and direction outputs are RS422 compatible and are capable of being connected in either differential mode or single ended configurations for 5V input drivers.

Below are two examples for wiring the Geo Brick drive to the stepper Amplifier. The user needs to write pin 8 to pin 4 so as to enable the Stepper output and the AENA.

GBL_Stepper output wiring X1-X8,
quadrature encoder feedback,
Amplifier Enable lines are used

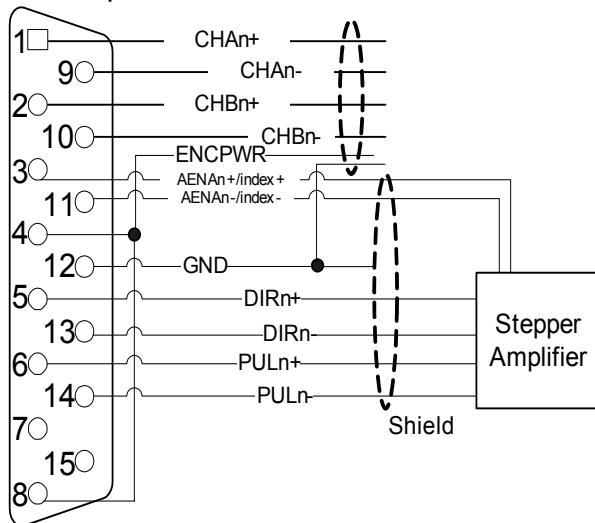

Short pin 8 to pin 4 to enable Stepper Output

GBL_Stepper output wiring X1-X8,
no encoder feedback
Amplifier Enable lines are used

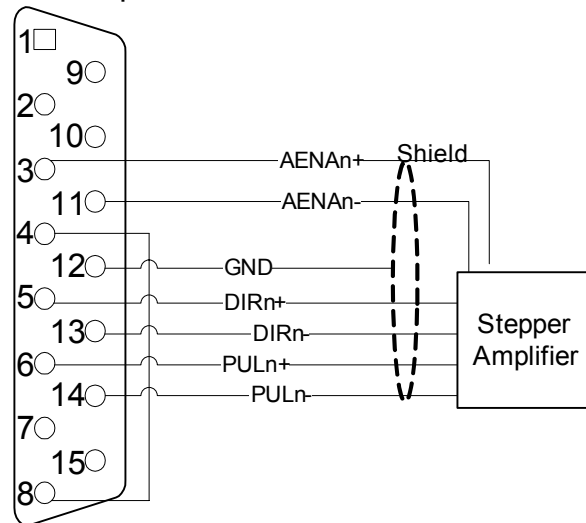

Short pin 8 to pin 4 to enable Stepper Output

(For Older version Geo Brick drives: Jumpers E21(E31) through E24(E34) must be jumpered in the inside of the unit for PFM outputs and E25(35) through E28(38) must be jumpered for amplifier enable outputs. Pin 8 was not connected to anything)

Software Setup

After having the hardware ready for steppers the user needs to set the software for Pulse and direction output as well. There are several I-variables that must be set up properly for proper operation of the Pulse and direction output in a Geo Brick system. It is recommended for the user to also look into the **Turbo Software reference** and the **Turbo Users** manual. The most important ones are analyzed below and we can separate them into two categories:

Multi-Channel Servo IC I-Variables

I7m00: Servo IC m MaxPhase/PWM Frequency Control

Typically, this will be set to the same value as the variable that controls the system clocks: I7000 (channels 1-4) I7100 (channels 5-8). If a different PWM frequency is desired, then the following constraint should be observed in setting this variable:

$$\frac{2 * PWMFreq(kHz)}{PhaseFreq} = \{ Integer \}$$

I7m03: Servo IC m Hardware Clock Frequency Control

The hardware clock frequencies for the Servo IC should be set according to the devices attached to it. There is no reason that these frequencies have to be the same between ICs. There is seldom a reason to change this value from the default. At default this value will be 2258, which is to a PFM clock of approximately 10 MHz, (which is about 10 times greater than normally needed). Therefore, this value is not normally changed. Refer to the Turbo Software Reference manual for changing these variables.

I7m04: PFM Pulse Width Control

The pulse width is specified in PFM clock cycles and has a range of 1 to 255 cycles. The default value is 15. Since the default value of PFM clock is actually set to 9.8304 MHz, the default output pulse width will be $15/9,830400 = 1.5258 \mu\text{S}$. Note that when the PFM clock values are changed, the PFM pulse width values must be evaluated for proper stepper drive operation.

The user of a typical stepper drive should not need to modify these control variables. However, PFM pulse width should be increased if the stepper drive's input cannot handle the speed of the pulse output. This often occurs with slow opto-couplers used on stepper drive inputs.

Single-Channel I-Variables

Each Servo IC has four channels *n*, numbered 1 to 4. For the first (standard) Servo IC on the Geo Brick, the channel numbers 1 – 4 on the Servo IC are the same as the channel numbers 1 – 4 on the board. For the second (optional) Servo IC on the Geo Brick, the channel numbers 1 – 4 on the Servo IC correspond to board channel numbers 5 – 8. The most important variables are:

I7mn0: Servo IC *m* Channel *n* Encoder Decode Control

Typically, I7mn0 is set to 3 or 7 for x4 quadrature decode, depending on which way is up. If the channel is used for open-loop stepper drive, I7mn0 is set to 8 to accept internal pulse-and-direction.

Caution:

If I7mn0 and I7mn8 are not matched properly, motor runaway will occur.

I7mn6: Servo IC *m* Channel *n* Output Mode Select

I7mn6 determines whether the A and B outputs are DAC or PWM, and whether the C output is PFM (pulse-and-direction) or PWM. Typically, it is set to 0, either for 3-phase PWM, or to 3 for DACs and PFM.

Set the output mode for the Geo Brick for Pulse Frequency Modulation output (PFM), I7mn6 equal to 2.

I7mn8: Servo IC *m* Channel *n* PFM Direction Signal Invert Control

The polarity of the direction output is controlled by this I-variable. This output establishes an active low or high output.

This I-variable works in conjunction with I7mn0. To operate correctly with the Geo Brick, if I7mn0 is set to 0, then I7mn8 is set to 0. If I7mn0 is set to 4, then I7mn8 is set to 1.

Caution:

If I7mn0 and I7mn8 are not matched properly, motor runaway will occur.

The Geo Brick applies its gain formulas the same way it does for a classic servo system. The basic difference with a stepper system is that most of the times, the typical encoder feedback interface is handled using electronic circuitry rather than a physical encoder.

When the stepper output interface is selected, it allows the use of an electronic encoder feedback or a physical encoder feedback. When used with an actual physical encoder, the axis should be tuned as if it were a typical servomotor.

The process of tuning the simulated feedback loop is identical to tuning a servomotor with the exception that some of the parameters become more predictable.

Ixx30: Motor xx Proportional Gain

To create a closed loop position response with a natural frequency of approximately 25 Hz and a damping ratio of 1, use the following calculation:

$$Ixx30 = \frac{660,000}{Ixx08 * PFMCLK (MHz)}$$

Example:

PFMCLK is set to default of 9.83 MHz, and Ixx08 is set to default of 96. $Ixx30 = 660,000 / (96 * 9.83) = 700$.

Ixx31 Motor x Derivative Gain

Derivative Gain is set to 0 because the motor system behaves like a velocity-loop servo drive. This parameter sets the system damping which should be unnecessary.

Ixx32 Motor xx Velocity Feedforward Gain

Use the following equation to establish a value for Ixx32:

$$Ixx32 = 6660 * ServoFreq (kHz)$$

where ServoFreq (kHz) is the frequency of the servo interrupt as established by I7m00, I7m01, and I7m02.

Example:

ServoFreq is set to default of 2.26 kHz (I7m00 = 6527, I7m01 = 0, I7m02 = 3). $Ixx32 = 6660 * 2.26 = 15,050$.

Note:

If Ixx30 were set differently from the above calculation, then Ixx32 would change inversely. For instance, if Ixx30 were twice the above calculation, then Ixx32 would be half its calculation.

Ixx33 Motor xx Integral Gain

Typically, This I-variable should be set to 0. The digital electronic loop does not present offsets or disturbances that need correction in the PMAC.

Ixx33 may be set to force zero steady-state errors, should they be present with electronic encoder feedback.

Ixx34 Motor xx Integration Mode

The default value of 1 is sufficient for this, since usually Ixx33 is set to zero. When Ixx33 is set to 0, this I-variable has no effect.

Ixx35 Motor xx Acceleration Feed-forward Gain

Start with this I-variable set to 0. Typically, this value does not need to be changed. However, Ixx35 might be adjusted to compensate for the small time delays created by the electronics when accelerating the stepper. The effect of adjusting Ixx35 will be to reduce a slight following error during motor acceleration.

Ixx36 - Ixx39 Motor xx Notch Filter Coefficients

These values should be set to their default value of 0. Since filter parameters adjust the way the gains operate due to physical resonance of a system, there is no need to set these I-variables.

Example: User wants channels 5 to 8 to be used with stepper motors. First the user needs to wire the Stepper drive, and so as to enable the Stepper output pin 8 needs to be shorted to pin 4 (+5V) for X5 to X8. Assume for this example that all the stepper motors that will be used do not have encoders for feedback.

For this example, the factory defaults for the other variables will allow the PFM outputs to be commanded with a low true Amplifier Fault and \pm Limits plugged in. If this is not the case, modify Ixx24.

For this type of system, make sure I7mn6 is set for PWM and PFM output mode.

```
I7116=2      ;CH5A and CH5B outputs will be PWM and CH5C output will be PFM
I7126=2      ;CH6A and CH6B outputs will be PWM and CH6C output will be PFM
I7136=2      ;CH7A and CH7B outputs will be PWM and CH7C output will be PFM
I7146=2      ;CH8A and CH8B outputs will be PWM and CH8C output will be PFM

I7110 = 8    ;Simulated feedback for channel 5
I7120 = 8    ;Simulated feedback for channel 6
I7130 = 8    ;Simulated feedback for channel 7
I7140 = 8    ;Simulated feedback for channel 8

I502=$078104 ;Command output to CH1A address (default address + 2) for
              ;Stepper
I602=$07810C ;Command output to CH2A address (default address + 2)
              ;for Stepper
I702=$078114 ;Command output to CH3C address (default address + 2)
              ;for Stepper
I802=$07811C ;Command output to CH4C address (default address +2)
              ;for Stepper
```

DIRECT PWM COMMUTATION CONTROLLER SETUP

The Geo Brick drive must have the proper controller setup to command the amplifier/motor system. This section summarizes the key variables for Turbo PMAC2 controllers that would have to be modified for use with the amplifier. The Delta Tau setup software such as Turbo Setup will help set these parameters for the system automatically. For details about direct commutation of brushless and induction motors, read the PMAC2 or Turbo PMAC2 User Manual. To find out the details about these variables, refer to the PMAC2 or Turbo PMAC2 Software Reference Manual.

Key Servo IC Variables

Turbo	Type	Description
I7m00	Clock	Max phase clock setting
I7m01	Clock Divisor	Phase clock divisor
I7m02	Clock Divisor	Servo clock divisor
I7m03	Clock	Hardware clock settings
I7m04	Clock	PWM dead time
I7m05	Strobe	DAC strobe word
I7m06	Strobe	ADC strobe word (Must be set to \$3FFFFFF for Geo drives.)
I7mn0	Channel	Encoder decode for channel
I7mn6	Channel	Output mode for channel (Must be set to 0.)

* m: stands for servo IC number. Channels 1 to 4 are on servo IC#0 so set I7006. For channels 5 to 8 set I7106
For example: I7006=\$3FFFFFF.

Key Motor Variables

Caution:

The ADC Strobe Word, I7m06 (Turbo), must be set to \$3FFFFFF for proper operation. Failure to set I7m06 equal to \$3FFFFFF could result in damage to the amplifier.

Turbo	Type	Description
Ixx00	General	Motor enable
Ixx01	General	Commutation enable
Ixx24 Ixx25	General	Motor flag setup
Ixx70	Commutation	Number of commutation cycles per Ix71
Ixx71	Commutation	Counts per commutation cycle per Ix70
Ixx72	Commutation	Commutation phase angle
Ixx77	Commutation	Induction motor magnization current
Ixx78	Commutation	Induction motor slip gain
Ixx83	Commutation	On-going phase position
Ix61	Current Loop	Current loop integrator gain
Ix62	Current Loop	Current loop forward path proportional gain
Ix66	Current Loop	PWM scale factor
Ix76	Current Loop	Current loop back bath proportional gain
Ix82	Current Loop	Current loop feedback address
Ix84	Current Loop	Current loop feedback ADC mask word
Ixx57	I ² T	Continuous limit for I2T
Ixx58	I ² T	Integrated current limit

DC BRUSH MOTOR DRIVE SETUP WITH TURBO PMAC

Commutation Phase Angle: Ixx72

Ixx72 controls the angular relationship between the phases of a multiphase motor. When Turbo PMAC is closing the current loop digitally for Motor xx, the proper setting of this variable is dependent on the polarity of the current measurements.

If the phase current sensors and ADCs in the amplifier are set up so that a positive PWM voltage command for a phase yields a negative current measurement value, Ixx72 must be set to a value less than 1024: 683 for a 3-phase motor, or 512 for a DC brush motor. If these are set up so that a positive PWM voltage command yields a positive current measurement value, Ixx72 must be set to a value greater than 1024: 1365 for a 3-phase motor, or 1536 for a DC brush motor. The testing described below shows how to determine the proper polarity.

The direct-PWM algorithms in the Turbo PMAC are optimized for 3-phase motors and will cause significant torque ripple when used with 2- or 4-phase motors. Delta Tau has created user-written phase algorithms for these motors; contact the factory if interested in obtaining these.

Note:

It is important to set the value of Ixx72 properly for the system. Otherwise, the current loop will have unstable positive feedback and want to saturate. This could cause damage to the motor, the drive, or both, if overcurrent shutdown features do not work properly. If unsure of the current measurement polarity in the drive, [consult the Testing PWM and Current Feedback Operation section of this manual.](#)

For commutation with digital current loops, the proper setting of Ixx72 is unrelated to the polarity of the encoder counter. This is different from commutation with an analog current loops (sine-wave control), in which the polarity of Ixx72 (less than or greater than 1024) must match the encoder counter polarity. With the digital current loop, the polarity of the encoder counter must be set for proper servo operation; with the analog current loop, once the Ixx72 polarity match has been made for commutation, the servo loop polarity match is guaranteed.

Special Instructions for Direct-PWM Control of Brush Motors

Special settings are needed to use the direct-PWM algorithms for DC brush motors. The basic idea is to trick the commutation algorithm into thinking that the commutation angle is always stuck at 0 degrees, so current into the A phase is always quadrature (torque-producing) current. These instructions assume:

- The brush motor's rotor field comes from permanent magnets or a wound field excited by a separate means; the field is not controlled by one of the phases of this channel.
- The two leads of the brush motor's armature are connected to amplifier phases (half-bridges) that are driven by the A and C-phase PWM commands from Turbo PMAC. The amplifier may have an unused B-phase half-bridge, but this does not need to be present.

The following settings are the same as for permanent-magnet brushless servo motors with an absolute phase reference:

- Ixx01 = 1 (commutation directly on Turbo PMAC) or Ixx01=3 (commutation over the MACRO ring)
- Ixx02 should contain the address of the PWM A register for the output channel used or the MACRO Node register 0 (these are the defaults), just as for brushless motors.
- Ixx29 and Ixx79 phase offset parameters should be set to minimize measurement offsets from the A and B-phase current feedback circuits, respectively.
- Ixx61, Ixx62, and Ixx76 current loop gains are set just as for brushless motors.

- $I_{xx73} = 0$, $I_{xx74} = 0$: These default settings ensure that Turbo PMAC will not try to do a phasing search move for the motor. A failed search could keep Turbo PMAC from enabling this motor.
- $I_{xx77} = 0$ to command zero direct (field) current.
- $I_{xx78} = 0$ for zero slip in the commutation calculations.
- I_{xx82} should contain the address of ADC B register for the feedback channel used (just as for brushless motors) when the ADC A register is used for the rotor (armature) current feedback. The B register itself should always contain a zero or near-zero value.
- $I_{xx81} > 0$: Any non-zero setting here makes Turbo PMAC do a “phasing read” instead of a search move for the motor. This is a dummy read, because whatever is read is forced to zero degrees by the settings of I_{xx70} and I_{xx71} , but Turbo PMAC demands that some sort of phase reference be done. ($I_{xx81}=1$ is fine.)
- I_{xx84} is set just as for brushless motors, specifying which bits the current ADC feedback uses. Usually, this is $\$FFF000$ to specify the high 12 bits.

Special settings for brush motor direct PWM control:

- $I_{xx70} = 0$: This causes all values for the commutation cycle to be multiplied by 0 to defeat the rotation of the commutation vector.
- $I_{xx72} = 512$ ($90^\circ e$) if voltage and current numerical polarities are opposite, 1536 ($270^\circ e$) if they are the same. If the amplifier would use 683 ($120^\circ e$) for a 3-phase motor, use 512 here; if it would use 1365 ($240^\circ e$) for a 3-phase motor, use 1536 here.
- $I_{xx96} = 1$: This causes Turbo PMAC to clear the integrator periodically for the (non-existent) direct current loop, which could slowly charge up due to noise or numerical errors and eventually interfere with the real quadrature current loop.

Settings that do not matter:

- I_{xx71} (commutation cycle size) does not matter because I_{xx70} setting of 0 defeats the commutation cycle
- I_{xx75} (Offset in the power-on phase reference) does not matter because commutation cycle has been defeated. Leaving this at the default of 0 is fine.
- I_{xx83} (ongoing commutation position feedback address) doesn't matter, since the commutation has been defeated. Leaving this at the default value is fine.
- I_{xx91} (power-on phase position format) does not matter, because whatever is read for the power-on phase position is reduced to zero.

Testing PWM and Current Feedback Operation

WARNING:

On many motor and drive systems, potentially deadly voltage and current levels are present. Do not attempt to work directly with these high voltage and current levels unless fully trained on all necessary safety procedures. Low-level signals on Turbo PMAC and interface boards can be accessed much more safely.

Most of the time in setting up a direct PWM interface, there is no need to execute all of the steps listed in these sections (or the Turbo Setup program will do them automatically). However, the first time this type of interface is setup, or there are problems, these steps will be of assistance.

For safety reasons, all of these tests should be done with the motor disconnected from any loads. All settings made as a result of these tests are independent of load properties, so will still be valid when the load is connected.

Before testing any of Turbo PMAC's software features for digital current loop and direct PWM interface, it is important to know whether the hardware interface is working properly. PMAC's M-Variables are used to access the input and output registers directly. The examples shown here use the suggested M-Variable definitions for Motor 1.

Purpose

The purpose of these tests is to confirm the basic operation of the hardware circuits on PMAC, in the drive, and in the motor, and to check the proper interrelationships. Specifically:

- Confirm operation of encoder inputs and decode
- Confirm operation of PWM outputs
- Confirm operation of ADC inputs
- Confirm correlation between PWM outputs and ADC inputs
- Determine proper current loop polarity
- Confirm commutation cycle size
- Determine proper commutation polarity

Preparation

First, define the M-Variables for the encoder counter, the three PWM output registers, the amplifier-enable output bit, and the two ADC input registers. Using the suggested definitions for Motor 1, utilizing Servo IC 0, Channel 1:

```
M101->X:$078001,0,24,S ; Channel 1 Encoder position register
M102->Y:$078002,8,16,S ; Channel 1 PWM Phase A command value
M104->Y:$078003,8,16,S ; Channel 1 PWM Phase B command value
M107->Y:$078004,8,16,S ; Channel 1 PWM Phase C command value
M105->Y:$078005,8,16,S ; Channel 1 Phase A ADC input value
M106->Y:$078006,8,16,S ; Channel 1 Phase B ADC input value
M114->X:$078005,14 ; Channel 1 Amp Enable command bit
```

Note:

The ADC values are declared as 16-bit variables even though typically, 12-bit ADCs are used; this puts the scaling of the variable in the same units as Ixx69, Ixx57, Ixx29, and Ixx79.

It is useful to monitor these values in the Watch window of the Executive program. Therefore, add the variable names to the Watch window which causes the program to repeatedly query Turbo PMAC for the values and display them. Then the hardware can be exercised with on-line commands issued through the Terminal window.

To prepare Turbo PMAC for these tests:

1. Set I100 to 0 to deactivate the motor.
2. Set I101 to 0 to disable commutation (This allows for manual use of these registers.)
3. Make sure that I7000, I7004, I7016, and I7017 are set up properly to provide the PWM signals desired.
4. If the Amplifier Enable bit is 1, set it to zero with the command **M114=0**.
5. Set Ixx00 and Ixx01 for all other motors to zero.

Position Feedback and Polarity Test

If the PWM command values observed in the Watch window are not zero, set them to zero with the command:

```
M102=0 M104=0 M107=0
```

The motor can be turned (or pushed) freely by hand now. As the motor is turned, monitor the M101 value in the Watch window. Look for the following:

- It should change as the motor is moved.
- It should count up in one direction, and count down in the other direction.
- It should provide the expected number of counts in one revolution or linear distance increment.
- As the motor is returned repeatedly to a reference position, it should report (approximately) the same position value each time.

If these things do not happen, check the encoder/resolver operation, its connection to Turbo PMAC and the Turbo PMAC decode variable I7mn0. Double-check that the sensor is powered. In addition, look at the encoder waveforms with an oscilloscope.

If the direction of motion to be the positive direction is known, check this here. If the direction is incorrect, invert it by changing I7mn0, usually from 7 to 3, or from 3 to 7. If the direction is not known, change it later, but make another change at that time to maintain the proper commutation polarity match; usually by exchanging two of the motor phase leads at the drive.

Note:

Because I100 has been set to 0, and I103 may not yet have been set properly, any change of position will not be reflected in the motor position window.

PWM Output and ADC Input Connection

WARNING:

Make sure before applying any PWM commands to the drive and motor in this fashion that the resulting current levels are within the continuous current rating of both drive and motor.

First, enable the amp, then apply a very small positive command value to Phase A and a very small negative command value to Phase B with the on-line commands:

```
M114=1 ; Enable amplifier
M102=I7000/50 M104=-I7000/50 M107=0 ; A pos, B neg, C zero
```

This provides a command at 2% of full voltage into the motor; this should be well within the continuous current rating of both drive and motor. It is a good idea to make the sum of these commands equal to zero so as not to put a net DC voltage on the motor; putting all three commands on one line causes the changes to happen virtually instantaneously.

With power applied to the drive and the amplifier enabled (**M114=1**), current readings should be received in the ADC registers as shown by the M-Variables M105 and M106 in the Watch window.

Since the M-Variables are defined as +/-32,768 for full current range, which should correspond approximately to the instantaneous current limit. Make sure that the value read does not exceed the continuous current limit, usually which is about 1/3 of the instantaneous limit. If well below the continuous current limit, increase the voltage command to 5% to 10% of maximum. For example:

```
M102=I7000/10 M104=-I7000/10 M107=0 ; 10% of maximum
```

PWM/ADC Phase Match

Command values from Turbo PMAC's Phase A PWM outputs should cause a roughly proportionate response of one sign or the other on Turbo PMAC's Phase A ADC input (whatever the phase is named in the motor and drive). The same is true for Phase B.

If no response is received on either phase, re-check the entire setup, including:

- Is the drive properly wired to Turbo PMAC, either directly or through an interface board?
- Is the motor properly connected to the drive?
- Is the drive properly powered, both the power stage, and the input stage?
- Is the interface board properly powered?
- Is the amplifier enabled (M114=1 on Turbo PMAC and indicator ON at the drive)?
- Is the amplifier in fault condition? If so, why?

If only an ADC response is received on one phase, the phase outputs and inputs may not be matched properly. For example, the Phase B ADC may be reading current from the phase commanded by the Phase C PWM output. Confirm this by trying other combinations of commands and checking which ADC responds to which phase command. If there is not a proper match, change the wiring between Turbo PMAC and the drive. Changing the wiring between drive and motor will not help here.

Synchronous Motor Stepper Action

With a synchronous motor, this command should cause the motor to lock into a position, at least weakly, like a stepper motor. This action may be received temporarily on an induction motor, due to temporary eddy currents created in the rotor. However, an induction motor will not keep a holding torque indefinitely at the new location.

Current Loop Polarity Check

Observe the signs of the ADC register values in M105 and M106. These two values should be of approximately the same magnitude, and must be of the opposite sign from each other. (Again, remember that these readings may appear noisy. Observe the base value underneath the noise.) If M105 is positive and M106 is negative, the sign of the PWM commands matches the sign of the ADC feedback values. In this case, the Turbo PMAC phase angle parameter I172 must be set to a value greater than 1024 (1365 for a 3-phase motor).

If M105 is negative and M106 is positive, the sign of the PWM commands is opposite that of the ADC feedback values. In this case, I172 must be set to a value less than 1024 (683 for a 3-phase motor).

Make sure your I172 value is set properly before attempting to close the digital current loops on Turbo PMAC. Otherwise positive feedback will occur, creating unstable current loops which could damage the amplifier and/or motor.

If M105 and M106 have the same sign, the polarities of the current sense circuitry for the two phases is not properly matched. In this case, something has been miswired in the drive or between Turbo PMAC and the drive to give the two phase-current readings opposite polarity. One of the phases will have to be fixed.

Do not attempt to close the digital current loops on Turbo PMAC until the polarities of the current sense circuitry for the two phases have been properly matched. This will involve a hardware change in the current sense wiring, the ADC circuitry, or the connection between them. As an extra protection against error, make sure that Ixx57 and Ixx58 are set properly for I²T protection that will shut down the axis quickly if there is saturation due to improper feedback polarity.

Troubleshooting

If not getting the current readings expected, probe the motor phase currents on the motor cables with a snap-on hall-effect current sensor. If the current is not seen when commanding voltages, check for phase-to-phase continuity and proper resistance when the motor is disconnected.

Setting I²T Protection

It is important to set the I²T protection for the amplifier/motor system for Turbo PMAC2 direct PWM commutation. Normally, an amplifier has internal I²T protection because it is closing the current loop. When Turbo PMAC2 is closing the current loop, the amplifier cannot protect itself or the motor from over heating. Either set up the I²T protection using one of the Setup Programs or set the Ixx69, Ixx57 and Ixx58 variables manually based on the following specifications:

Parameter	Description	Notes
MAX ADC Value	Maximum Current output of amplifier relative to a value of 32767 in Ixx69	5A/10A peak 2secs, axis: 16.26A 8A/16A peak 2secs, axis: 26.02A 15A/30A peak 2secs, axis: 48.8A
Instantaneous Current Limit	The lower of the amplifier or motor system	RMS or Peak*
Continuous Current Limit	The lower of the amplifier or motor system	Usually RMS
I ² T protection time	Time at instantaneous limit	Two seconds
Magnetization Current	Ixx77 value for induction motors	Only for induction motors
Servo Update Frequency	Default is 2258 Hz.	
* If specification given in RMS, multiply with x1.41 to obtain peak current for calculations.		

Example Calculations for Direct PWM Commutated Motor:

MAX ADC = 26.02

Instantaneous Current Limit = 10A Peak

Continuous Current Limit = 5A RMS

I²T protection time = 2 seconds

Magnetization Current (Ixx77) = 0

Servo Update = 2.258 kHz

$$I_{xx69} = \frac{I_{ns \tan \tan eous \ Limit} (Peak)}{MAX \ ADC} \times 32767 \times \cos(30^\circ)$$

if calculated Ixx69 > 32767, then Ixx69 should be set equal to 32767

$$I_{xx57} = \frac{Continuous \ Limit}{I_{ns \ tan \ tan \ eous \ Limit}} \times I_{xx69}$$

$$I_{xx58} = \frac{I_{xx69}^2 + I_{xx77}^2 - I_{xx57}^2}{32768^2} \times ServoUpdateRate(Hz) \times PermittedTime(sec \ onds)$$

Based on the above data and equations, the following results:

Ixx69 = 10,906

Ixx57 = 5,435

Ixx58 = 376

For details about I²T protection, refer to the safety sections of the Turbo Users Manual. Details about the variable setup can be found in the Software Reference manual.

Calculating Minimum PWM Frequency

The minimum PWM frequency requirement for a system is based on the time constant of the motor. Calculate the minimum PWM frequency to determine if the amplifier will properly close the current loop. Systems with very low time constants need the addition of chokes or in-line inductive loads to allow the PMAC to properly close the current loop of the system. In general, the lower the time constant of the system, the higher the PWM frequency must be.

Calculate the motor time constant by dividing the motor inductance by the resistance of the phases.

$$\tau_{motor} = \frac{L_{motor}}{R_{motor}}$$

The relationship used to determine the minimum PWM frequency is based on the following equation:

$$\tau > \frac{20}{2\pi \times PWM(Hz)}$$
$$\therefore PWM(Hz) > \frac{20}{2\pi\tau}$$

Example:

$$L_{motor} = 5.80 \text{ mH}$$

$$R_{motor} = 11.50 \Omega$$

$$\tau_{motor} = \frac{5.80\text{mH}}{11.50\Omega} = 0.504\text{m sec}$$

$$\text{Therefore, } PWM(Hz) = \frac{20}{2\pi \times (0.504\text{m sec})} = 6316 \text{ Hz}$$

Based on this calculation, set the PWM frequency to at least 6.32kHz.

Amplifier Only Special online commands

With the Geo Brick Amplifiers a new version of firmware was created to help the user identify the unit easier. If the user uses the "TYPE" on-line command and PMAC responds and there is a word AMP, then your drive has the latest Amplifier firmware.

New TYPE and CID commands on detection of a TURBO2 type AMP

TYPE

TURBO2, AMP, Xn

CID

603793

All of the "AMP" commands, i.e., commands that begin with "AMP" are read only commands. These commands automatically disable any axes that are enabled. The commands report such things as the amplifier firmware version, number model and ID.

Note:

All "AMP" commands are working only with the Geo Brick drives that have the 1.942A and above firmware, and the amplifier CPU firmware version is B1.06 and above.

AMPVERSION

Function: Report Amplifier CPU firmware version number

Scope: Global

Syntax: **AMPVERSION**

AMPVER

This command causes the amplifier to report the firmware version it is using. The response is a hex value \$xxyyzz. xx: stands for the Amplifier type

yy & zz stands for the firmware version. (yy: Major, zz: Minor)

Geo Brick Drives are Amp type 01.

Example:

```
AMPVER ; Ask the PMAC/amplifier for firmware version
$01B106 ; PMAC/amplifier responds
```

AMPMOD

Function: Report Amplifier Model Number

Scope: Global

Syntax: **AMPMOD**

This command causes the amplifier to report its model number. The response is an ASCII numeric.

Example:

```
AMPMOD ; Ask the PMAC/amplifier for the Amplifier model number
GBL4-C0-506-14S ; PMAC/amplifier responds with its factory set model number
```

AMPSID

Function: Report serial electronic identification number

Scope: Global

Syntax: **AMPSID**

This command causes Turbo PMAC to report the electronic identification number from the ID-number module. The identification number is reported as a hexadecimal 16-digit ASCII string, representing a 64-bit value. The first two hex digits represent the 8-bit checksum value for the module; these should match the checksum digits engraved on the case of the module. The last two hex digits represent the module class; these should match the class digits engraved on the case of the module. The middle 12 hex digits represent the unique number for each module and board.

If no ID-number module is present, Turbo PMAC will return a 0.

The electronic identification number has no relationship to the serial number that is engraved or barcoded on the circuit board.

Example:

AMPSID

272F0000000800

PWM DRIVE COMMAND STRUCTURE

The amplifier functions in two modes: Default and Enhanced.

Default Mode

Default Mode is the mode the amplifier is in when it is first powered on or the power is re-cycled for any reason. Default mode is compatible with the full series of Delta Tau amplifiers and the A/D converters used on these amplifiers. In this mode, the amplifier returns not only the currents for phases A and B but also the fault codes for the axes associated with those currents. The fault codes occupy the lower 12-bits on each phase. For Default mode to work correctly, make sure that the A/D strobe word for the axis is set to the correct value for the A/D on the amplifier. For instance, the current Delta Tau amplifiers use a 12-bit Burr Brown part requiring a strobe word of \$3FFFFFF; this word is written to **I7m06= \$3FFFFFF**.

This value can be saved to PMAC memory and sent to the amplifier on boot automatically.

Enhanced Mode

Enhanced mode is available on the Geo series of Delta Tau amplifiers and offers many more options. Like the Default mode, Enhanced mode requires that a special strobe word be written to the amplifier, and like Default mode, this word may be saved to PMAC memory and issued each boot automatically. Enhanced mode axes and Default mode axes may not be mixed on the same amplifier.

Enhanced mode not only offers the fault codes associated with any axis on the bits 11:4 of the current feedback, but provides the means for reading both bus voltage and IGBT temperatures.

To enter Enhanced Mode, the Strobe Word must be set to

ADC Strobe Word	Value	Description
I7m06	\$300FFF	IGBT Temperature reported on phase B for each axis at the IC
	\$301FFF	Bus Voltage reported on phase B for each axis at the IC
	\$3FDFFF	Firmware Major version number in 00.00 (major.minor) format
	\$3FEFFF	Firmware Minor version number in 00.00 (major.minor) format
	\$3FFFFFF	Default mode

At present, the commands sent to axis one/five, are active on all axes of the specific IC of the amplifier, that is, if bus voltage from axis one is requested, bus voltage from axes 1 to 4 on that IC of the amplifier will be received.

IGBT temperature:

For every 2.13 degrees Celsius there is an additional count at the ADC register, +1h. The baseline temperature is set at 25°C, which means the ADC has a value of 21h. The maximum IGBT temperature for the Geo Brick drives is 125° Celsius, 5Bh.

Bus Voltage:

For every 5.875Volts there is an additional count at the ADC register, +1h. The maximum Bus Voltage for the Geo Brick Drives is 420VDC, (296VAC) before over voltage fault, which means the ADC has a value of 50h. The Shunt resistor turn on voltage is 388.5V, the value is 4Ah, and the turn off voltage is 367.5, a value of 46h.

TROUBLESHOOTING

The Geo Brick utilizes a scrolling single-digit 7-segment display. When control power is applied to the drive, the 7-segment display will have a blinking “.” (period) indicating that the software and hardware are running normally. This blinking period is running all of the time except if the PMAC CPU has faulted, then it stays on. When any of the drive’s output sections are enabled, the display will include a “0”. When all axes are not enabled and there is no Fault, the display will be blank with the blinking “.” (period).

Important:

The purpose of the notice below is to make sure that the Geo Brick Drive is being configured properly at power-up for normal mode operations

This note does not apply to Amplifier code version **\$010200** (returned by the **AMPVER** command), and PMAC firmware version 1.944 (returned by the **VER** command) and higher. The **AMPVER** command or startup PLC are not required for those latest firmware releases.

Important Note:

For Geo Brick PMAC firmware versions 1.943 and below, a delay of about 500 milliseconds and an **AMPVER** command are necessary at startup to ensure proper drive setup. PLC example below.

```
OPEN PLC 1 CLEAR
DIS PLC 2..31
I5111=500*8388608/I10 ; 500 ms delay using C.S1 countdown timer
WHILE (I5111>0)
END WHILE
CMD"AMPVER"
I5111=20*8388608/I10 ; 20 ms delay using C.S1 countdown timer.
WHILE (I5111>0) ; This provides enough time for the drive
END WHILE ; to process the ampver command.
ENAPLC 2..31
DISABLE PLC1
CLOSE
```

Quick Test:

The TYPE command, issued from a terminal window, should then show AMP separating Turbo2 and the CPU speed option (i.e., TURBO2, AMP, X4). This is the desired response. A response of TURBO2, X4 is not appropriate for the Geo Brick and it implies that the PLC has not executed properly (i.e., I5 setting) and/or an AMPVER command has not been issued at power-up.

Error Codes

The drive will produce a 3-character scrolling display whenever a fault on any axis exists. The scrolling display begins with a number indicating the axis that has faulted or **A** for global faults, followed by the **F** character – indicating a fault exists, followed by the specific fault code. There is a blank pause between the fault code and the beginning axis number of the scrolling display to distinguish between the beginning and the end of the scrolling codes. The table below lists the fault codes.

Note:

The Geo Brick Drive disables automatically at the occurrence of a fault.

D1: Geo Brick Drive Status Display Codes

The 7-segment display on the current model, 16 numeric codes plus two decimal points, provides the following codes:

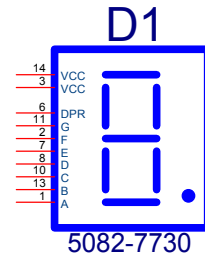

Display Fault code	ADC bits 11:4 Fault code	Description
Axis faults : n stands for axis number (n=1-8)		
n F1	01	Axis n Peak Current Fault – indicates the peak current was excessive long enough to trip the peak current fault, but there was not enough current to cause a nF3 fault (described below). Check for overshoots in the current loop, make sure Ixx69 is less or equal to 24676
n F2	02	Axis n RMS Current Fault – indicates the continuous or RMS current rating of the drive has been exceeded. Check for binding in motor, check if the motor is properly phased.
n F3	03	Axis n Short Circuit Fault – indicates high output current has been detected (fast acting). Unplug the Motor lead connectors and, if the fault persists, send the drive for RMA. Else check your motor and cable. Do not reset until unplugging motor cable and checking out the cause for the fault or permanent damage could result!
n F4	--	Reserved for future use
n F5	05	Power Stage (IGBT) Over-Temperature Fault – indicates excessive temperature has been detected. Check ambient temperature that it does not exceed the limits. Power off the drive and let it cool down. If the drive is cool and the fault persists, send the drive for RMA
n F6 - n FF	--	Reserved for future use
0	FF	Axis Enabled, drive is functioning properly.
Global Faults		
AF1	04	PWM over frequency fault – indicates the PWM frequency detected by the drive exceeds specified limits. Check your settings (I-vars)
AF2	0B	Strobe Word Fault – not valid strobe word \$3FFFFFF
AF3	0D	EEPROM Communication Fault – make sure the drive is properly grounded. If problem persists, send the drive for RMA.
AF4	0E	Shunt RMS Fault – The shunt will stay on continuously for only 2 seconds.
AF5	0F	Soft Start Fault – Check the AC mains, if fault persists, send for RMA
AFb	07	Bus Over-Voltage Fault – indicates either that excessive bus voltage has been detected, or no bus voltage at all has been detected, so check your bus supply, regen resistors (GARxx).
AFd	09	Shunt Short Circuit Fault – check the shunt resistor leads for short. If the connector is unplugged and the error persists, send the drive for RMA.
AFU	08	Bus Under-Voltage Fault – indicates that not enough bus voltage has been detected, check the DC bus to ensure that more than 10V exists.
AFL	0C	AC Line monitor – check the AC mains for more than 97VAC.
U		EPROM got corrupted. Call factory for assistance

Status LEDs

LED	Function	Color	Description
EN5	Enable Axis #5	Green	Green when fifth axis enabled (analog output). (Only when the analog I/O is ordered.) (Unlit does not necessarily mean fault.)
EN6	Enable Axis #6	Green	Green when sixth axis enabled (analog output). (Only when the analog I/O is ordered.) (Unlit does not necessarily mean fault.)
EN7	Enable Axis #7	Green	Green when seventh axis enabled (analog output). (Only when the analog I/O is ordered.) (Unlit does not necessarily mean fault.)
EN8	Enable Axis #8	Green	Green when eighth axis enabled (analog output). (Only when the analog I/O is ordered.) (Unlit does not necessarily mean fault.)
+5V	Logic Power	Green	Lit when 5V logic has power.
WD	WatchDog	Red	Lit when Watchdog is tripped.
BUS	DC Bus Voltage	Red	Lit when bus is powered.
ABORT ACTIVE		Red	Lit when ABORT is True
ABORT INACTIVE		Green	Lit when ABORT is not True
In older versions of the Geo Brick, the ABORT LEDs and the inputs at X15 were not available.			

Watchdog Timer

Geo Brick has an on-board watchdog timer. This subsystem provides a fail-safe shutdown to guard against software and hardware malfunction. To keep it from tripping the hardware circuit for the watchdog timer requires that two basic conditions be met. First, it must see a DC voltage greater than approximately 4.75V. If the supply voltage is below this value, the circuit's relay will trip and the card will shut down, Geo Brick uses its own DC to DC converter to create 5V and +/-15V from the user supplied 24VDC. This prevents corruption of registers due to insufficient voltage.

The second necessary condition is that the timer must see a square wave input (provided by the Turbo PMAC software) of a frequency greater than approximately 25 Hz. In the foreground, the servo-interrupt routine decrements a counter (as long as the counter is greater than zero), causing the least significant bit of the timer to toggle. This bit is fed to the timer itself. At the end of each background cycle, the CPU resets the counter value to a maximum value set by variable I40 (or to 4096 if I40 is set to the default of 0). If the card, for whatever reason, due either to hardware or software problems, cannot set and clear this bit repeatedly at 25 Hz or greater, the timer will trip and the Turbo PMAC system will shut down.

Actions on Watchdog Timer Trip

When the timer trips due to either under-voltage or under-frequency, the system is latched into a reset state, with a red LED indicating watchdog failure. The processor stops operating and will not communicate. All Servo, MACRO, and I/O ICs are forced into their reset states, which force discrete outputs off, and proportional outputs (DAC, PWM, PFM) to zero-level.

In Turbo PMAC2 systems there is a hard-contact relay with both normally open and normally closed contacts. In a system, these outputs should be used to drop power to the amplifiers and other key circuitry if the card fails.

Once the watchdog timer has tripped, power to the Turbo PMAC must be cycled off and on, or the INIT/hardware reset line must be taken low, then high, to restore normal functioning.

Diagnosing Cause of Watchdog Timer Trip

Because the watchdog timer is designed to trip on a variety of hardware and software failures, and the trip makes it impossible to query the card, it can be difficult to determine the cause of the trip. The following procedure is recommended to figure out the cause:

1. Reset the Turbo PMAC normally, just power cycle the cycle owner. If it does not trip again immediately, there is an intermittent software or hardware problem. Check for the following:
 - Software events that overload the processor at times (e.g. additional servo-interrupt tasks, intensive lookahead) or possible erroneous instruction (look for firmware or program checksum). Review the Evaluating the Turbo PMAC's Computational Load section of the Turbo USERS manual.
 - 5V power-supply disturbances
 - Loose connections
2. If there is an immediate watchdog timer trip in Step 1, power up with the re-initialization switch pressed and hold in. If it does not trip now, there is a problem in the servo/phase task loading for the frequency, or an immediate software problem on the board. Check for the following:
 - Phase and servo clock frequencies vs. the number of motors used by Turbo PMAC. These frequencies may need to be reduced.
 - A PLC 0 or PLCC 0 program running immediately on power-up (I5 saved at 1 or 3) and taking too much time.
 - User-written servo or phase program not returning properly.
3. If there is an immediate watchdog timer trip in Step 2, check for hardware issues:
 - Disconnect any accessories and cables other than the logic power and repeat to see if they are causing the problem
 - Check for adequate 24V power supply levels (check at the Geo Brick connector side, not at the supply)
 - Inspect for hardware damage
5. If the watchdog insists after all the above, you should contact DeltaTau Inc. to get an RMA number, and ship the drive for repairs.

APPENDIX A

Mating Connector and Cable Kits

Cable sets can be purchased directly from Delta Tau to make the wiring of the system easier. Available cable kits (CABKITxx) are listed below.

However, for those who wish to manufacture their own cable sets, the table below provides Connector Kits to use with each drive. Connector Kits (CONKITxx) include the MOLEX connectors and pins for the AC input, 24VDC power supply and the motor outputs.

Note:

Due to the variety and wide availability of D-type connectors and back shells, CABKITs and CONKITs do not provide these connectors and back shells. Cable kits have terminated cables on the drive end and flying leads on the other.

CONKIT5A	Mating Connector Kit for four axes drives up to 10-amp continuous rating. Includes Molex Connectors kits for four motors, AC input connection, Regen Resistor connector and 24V power connection. Requires Molex Crimp Tools for proper installation.
CABKIT5A	Includes Molex mating connectors pre-crimped for four axes drives up to 10-amp continuous rated <ul style="list-style-type: none"> • 3 ft. AC Input Cable • 3 ft. 24VDC Power Cable • (x4) 10 ft. shielded Motor Cables
CONKIT5B	Mating Connector Kit for six axes drives. Four axes are up to 10-amp continuous rating and two more axes up to 15A continuous. Includes Molex Connectors kits for six motors, AC input connection, Regen Resistor connector and 24V power connection. Requires Molex Crimp Tools for proper installation.
CABKIT5B	Includes Molex mating connectors pre-crimped for six axes drives. Four axes are up to 10-amp continuous rating and two more axes up to 15A continuous. <ul style="list-style-type: none"> • 3 ft. AC Input Cable • 3 ft. 24VDC Power Cable • (x6) 10 ft. shielded Motor Cables
CONKIT5C	Mating Connector Kit for eight axes drives up to 10-amp continuous rating. Includes Molex Connectors kits for eight motors, AC input connection, Regen Resistor connector and 24V power connection. Requires Molex Crimp Tools for proper installation.
CABKIT5C	Includes Molex mating connectors pre-crimped for eight axes drives up to 10-amp continuous rated <ul style="list-style-type: none"> • 3 ft. AC Input Cable • 3 ft. 24VDC Power Cable • (x8) 10 ft. shielded Motor Cables
Molex Tools Part numbers for all CONKIT's: 63811-0400 63811-1500 11-01-0185	

CONKIT5A

Connector	D/T part number	D/T part number individuals	Molex part number
24VDC	200-043645-200	Housing: #014-043645-200 Pins: #014-043030-008	43645-0200 43030-0007/-0008/-0009
Motor (x4)	200-000F04-HSG	Housing: #014-000F04-HSG Pins: #014-043375-001	44441-2004 43375-0001
AC Input	200-H00F04-049	Housing: 014-H00F04-049 Pins: 014-042815-031	42816-0412 42815-0031
Shunt Resistor	200-000F02-HSG	Housing: 014-000F02-HSG Pins: 014-043375-001	44441-2002 43375-0001

CONKIT5B

Connector	D/T part number	D/T part number individuals	Molex part number
24VDC	200-043645-200	Housing: #014-043645-200 Pins: #014-043030-008	43645-0200 43030-0007/-0008/-0009
Motor (x4)	200-000F04-HSG	Housing: #014-000F04-HSG Pins: #014-043375-001	44441-2004 43375-0001
Motor (x2)	200-H00F04-049	Housing: 014-H00F04-049 Pins: 014-042815-031	42816-0412 42815-0031
AC Input	200-H00F04-049	Housing: 014-H00F04-049 Pins: 014-042815-031	42816-0412 42815-0031
Shunt Resistor	200-H00F03-049	Housing: 014-H00F03-049 Pins: 014-042815-031	42816-0312 42815-0031

CONKIT5C

Connector	D/T part number	D/T part number individuals	Molex part number
24VDC	200-043645-200	Housing: #014-043645-200 Pins: #014-043030-008	43645-0200 43030-0007/-0008/-0009
Motor (x8)	200-000F04-HSG	Housing: #014-000F04-HSG Pins: #014-043375-001	44441-2004 43375-0001
AC Input	200-H00F04-049	Housing: 014-H00F04-049 Pins: 014-042815-031	42816-0412 42815-0031
Shunt Resistor	200-000F02-HSG	Housing: 014-000F02-HSG Pins: 014-043375-001	44441-2002 43375-0001

PWM Cable Ordering Information

Cable	Length						Part Numbers
	600mm (24")	900mm (36")	1.5m (60")	1.8m (72")	2.1m (84")	3.6m (144")	
CABPWM-1	✓						200-602739-024X
CABPWM-2		✓					200-602739-036x
CABPWM-3			✓				200-602739-060x
CABPWM-4				✓			200-602739-072x
CABPWM-5					✓		200-602739-084x
CABPWM-6						✓	200-602739-144x

Cable Drawings

5A/10A and 8A/16A Motor Cable

REVISIONS			
REV.	DESCRIPTION	DATE	CHKD. APPROVED
---	NEW DRAWING RELEASE	2-09-05	N.C. BRAD L

THIS DOCUMENT IS THE CONFIDENTIAL PROPERTY OF DELTA TAU DATA SYSTEMS INC. AND IS LOANED SUBJECT TO RETURNATION DEMAND. TITLE TO THIS DOCUMENT IS NEVER SOLD OR TRANSFERRED FOR ANY REASON. THIS DOCUMENT IS TO BE USED ONLY FOR THE PROJECT AND NOT BE REPRODUCED OR COPIED WITHOUT THE WRITTEN PERMISSION OF DELTA TAU DATA SYSTEMS INC. ALL RIGHTS TO DESIGN AND INVENTIONS ARE RESERVED BY DELTA TAU DATA SYSTEMS INC. POSSESSION OF THIS DOCUMENT IMPLICATES ACCEPTANCE OF THE ABOVE AGREEMENT.

LENGTH XXX ±3"

1.50" ±.25

UNTERMINATED

30

10 20

U-WHT
V-BLU
W-BLK
GRN

4
3
2
1

TABULATION	
-XXXX	DESCRIPTION
-0100	10 FEET
-0200	20 FEET

PARTS LIST		
SEQ	QTY	DESCRIPTION
10	1	RECEPTACLE, TERMINAL HOUSING 4 PIN (MOLEX P/N 44441-2004)
20	4	CRIMP TERMINAL (MOLEX P/N 43375-0001) REQUIRES MOLEX CRIMP TOOL P/N 63811-0400
30	XX FT	CABLE; 4 CONDUCTOR 14 AWG, SHIELDED (DELTA TAU P/N 023-14B004-05H)

NOTES: UNLESS OTHERWISE SPECIFIED

- PART NOS. ARE INTERPRETED AS FOLLOWS:
THE FIRST 3 DIGITS OF THE SUFFIX DENOTES LENGTH AND THE LAST DIGIT OF THE SUFFIX DENOTES REVISION LEVEL. ALL LENGTHS ARE SPECIFIED IN INCHES.
200-603839-0241 IS A REVISION 1 CABLE AND IS 24 FEET LONG.
- CABLE/HARNESS ASSEMBLIES TO BE MADE WITH UL RECOGNIZED COMPONENTS AND LABELED UNDER WIRING HARNESS PROGRAM ZPFW2 AND MEET CSA STANDARD 22:2 ND.0-M1982.
- CABLE TO BE IDENTIFIED WITH PART NUMBER AND REVISION USING BLACK INDELIBLE INK PRINTED ON LABEL. LABEL TO BE PERMANENTLY ATTACHED TO CABLE.

DELTA TAU DATA SYSTEMS, INC.

CABLE ASSY, MOTOR 3 PH, APPLICABLE TO
GEO BRICK MODELS

SIZE DWG. NO. 200-603839 DASH NO. ---
REV. ---

SCALE NONE SHEET 1 OF 1

15A/30A Motor Cable

THIS DOCUMENT IS THE CONFIDENTIAL PROPERTY OF DELTA TAU DATA SYSTEMS INC. AND IS LOANED SUBJECT TO RETURN UPON DEMAND. IT IS NOT TO BE REPRODUCED, COPIED, REPRODUCED, TRANSMITTED OR IN ANY MANNER. THIS DOCUMENT IS TO BE USED ONLY PURSUANT TO WRITTEN LICENSE OR WRITTEN INSTRUCTIONS OF DELTA TAU DATA SYSTEMS INC. ALL RIGHTS TO DESIGN AND INVENTION ARE RESERVED BY DELTA TAU DATA SYSTEMS INC. ACCEPTANCE OF THIS DOCUMENT INDICATES ACCEPTANCE OF THE ABOVE AGREEMENT.

TABULATION	DESCRIPTION
-XXXX	10 FEET
-0100	20 FEET
-0200	

INSTALL CRIMP LOCK,
SUPPLIED WITH ITEM 10

REV.	DESCRIPTION	DATE	CHGD.	APPROVED
--	NEW DRAWING RELEASE	1-03-05	N.G.	BRAD L.
-A	REVERSED U & W	2-09-05	N.G.	BRAD L.

NOTES: UNLESS OTHERWISE SPECIFIED

- PART NOS. ARE INTERPRETED AS FOLLOWS:
THE FIRST 3 DIGITS OF THE SUFFIX DENOTES LENGTH AND THE LAST DIGIT OF THE SUFFIX DENOTES REVISION LEVEL. ALL LENGTHS ARE SPECIFIED IN INCHES.
2C0-603838-0241 IS A REVISION 1 CABLE AND IS 24 FEET LONG.
- CABLE/HARNESS ASSEMBLIES TO BE MADE WITH UL RECOGNIZED COMPONENTS AND LABELED UNDER WIRING HARNESS PROGRAM ZPFW2 AND MEET CSA STANDARD 22.2 ND.0-M1982.
- CABLE TO BE IDENTIFIED WITH PART NUMBER AND REVISION USING BLACK INDELIBLE INK PRINTED ON LABEL. LABEL TO BE PERMANENTLY ATTACHED TO CABLE.

SEQ	QTY	DESCRIPTION
10	1	RECEPTACLE, TERMINAL HOUSING 4 PIN (MOLEX P/N 42816-0412)
20	4	CRIMP TERMINAL (MOLEX P/N 42815-0031) REQUIRES MOLEX CRIMP TOOL P/N 63811-1500
30	XX FT	CABLE, 4 CONDUCTOR 10 AVG. UNSHIELDED (ANIXTER P/N 4A-1004)

PROJECT	DATE	SCALE	SHEET
DELTA TAU DATA SYSTEMS,	1-03-05	NONE	1 OF 1

3-Phase power cable

REV.	DESCRIPTION	DATE	CHGD	APPROVED
--	NEW DRAWING RELEASE	1-03-05	N.G.	BRAD L.

REV.	DESCRIPTION	DATE	CHGD	APPROVED
--	NEW DRAWING RELEASE	1-03-05	N.G.	BRAD L.

SEQ.	QTY.	DESCRIPTION
10	1	RECEPTACLE, TERMINAL HOUSING 4 PIN (MOLEX P/N 42816-0412)
20	4	CRIMP TERMINAL (MOLEX P/N 42815-0031) REQUIRES MOLEX CRIMP TOOL P/N 63811-1500
30	XX FT.	WIRE, BLACK 10 AWG, 3 EQUAL LENGTHS (ANIXTER P/N 1015-10-0)
40	XX FT.	WIRE, GREEN 10 AWG, (ANIXTER P/N 1015-10-5)

NOTES: UNLESS OTHERWISE SPECIFIED

- PART NOS. ARE INTERPRETED AS FOLLOWS:
THE FIRST 3 DIGITS OF THE SUFFIX DENOTES LENGTH AND THE LAST DIGIT OF THE SUFFIX DENOTES REVISION LEVEL. ALL LENGTHS ARE SPECIFIED IN INCHES.
2C1-603838-0241 IS A REVISION 1 CABLE AND IS 24 FEET LONG.
- CABLE/HARNESS ASSEMBLIES TO BE MADE WITH UL RECOGNIZED COMPONENTS AND LABELED UNDER WIRING HARNESS PROGRAM ZPFW2 AND MEET CSA STANDARD 22.2 NDJ0-M1982.
- CABLE TO BE IDENTIFIED WITH PART NUMBER AND REVISION USING BLACK INDELIBLE INK PRINTED ON LABEL. LABEL TO BE PERMANENTLY ATTACHED TO CABLE.

INSTALL CRIMP LOCK SUPPLIED WITH ITEM 10

TABULATION	DESCRIPTION
-XXXX	3 FEET

REVISIONS

REV.	DESCRIPTION	DATE	CHGD	APPROVED
--	NEW DRAWING RELEASE	1-03-05	N.G.	BRAD L.

DELTA TAU	DATA SYSTEMS, INC.	CABLE ASSY, AC INPUT 3 PH, MODELS GXX201 & GXX301	SIZE (DWG. NO.) 2C1-603838	DASH NO. -XXXD	REV. -
			SCALE NONE	SHEET 1	OF 1

Regenerative Resistor: GAR48/78

Model	Description
GAR48	300W, 48 OHM regenerative resistor with Thermostat protection. Includes 18-inch wire cable. Single or dual axis.
GAR78	300W, 78 OHM regenerative resistor with Thermostat protection. Includes 18-inch wire cable. Single or dual axis.

THIS DOCUMENT IS THE CONFIDENTIAL PROPERTY OF DELTA TAU DATA SYSTEMS, INC. AND IS LOANED SUBJECT TO RETURN UPON DEMAND. TITLE TO THIS DOCUMENT REMAINS SOLELY OR TRANSFERRED FOR ANY REASON, THIS DOCUMENT IS TO BE USED ONLY PURSUANT TO WRITTEN LICENSE OR WRITTEN INSTRUCTIONS OF DELTA TAU DATA SYSTEMS, INC. ALL RIGHTS TO PATENTS AND INVENTIONS ARE RESERVED BY DELTA TAU DATA SYSTEMS, INC. POSSESSION OF THIS DOCUMENT INDICATES ACCEPTANCE OF THE ABOVE AGREEMENT.

REVISIONS				
REV	DESCRIPTION	DATE	CHG	APPROVED
--	NEW DRAWING RELEASE	2-04-03	N.G.	BILL K.

Specifications:
 Continuous Wattage: 300 Watts
 Hi Pot: 2500VAC 1 Second
 Thermostat:
 Normally Closed
 115VAC, 1 Amp
 Open at 227 +/- 11 degrees C.
 Ohms:
 008-0GAR48 is 48 ohms
 008-0GAR78 is 78 Ohms
 Leads:
 Resistor: 18 Inch High Temp, 14 AWG Min, White
 Thermostat: 18 Inch High Temp, 16 AWG Min, Black

Vendor Reference Numbers:
 008-0GAR48: SPR822-1
 008-0GAR78: SPR822-2
 IRV Series

NOTE:
 1. SILKSCREEN SIDES SHOWN PER ARTWORK.
 008-0GARxx-ART. USING BLACK EPDXY INK.

UNLESS OTHERWISE SPECIFIED DIMENSIONS ARE IN INCHES TOLERANCES ARE: FRACTIONS DECIMALS WHOLE ± FRACTION ± DEC ± INCH	PROJECT	008-BOOK AMP	DELTA TAU DATA SYSTEMS, INC.	
	REV LEVEL	MULTIPLE ASSY		
MATERIAL	DESIGNER	ROCK A. GOMEZ 02-04-03	RESISTOR, SHUNT REGULATOR, 48 & 78 Ohm 300W MAX	
	SEE NOTES	APPROVED	SCALE	DRAWING NO. 008-0GARXX
DO NOT SCALE DRAWING	DATE	02-04-03	SCALE	NONE
				DRAWING NO. 008-0GARXX
				SHEET 1 OF 1

DB- Connector Spacing Specifications

X1-8: DB-15 Connectors for encoder feedback

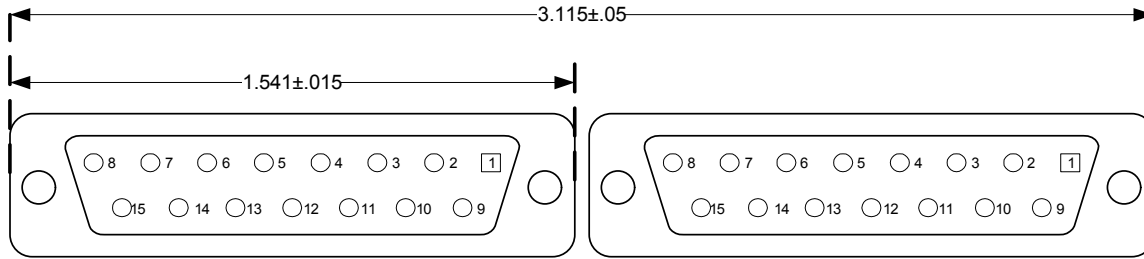

X9-12: DB-9 Connectors for Analog I/O

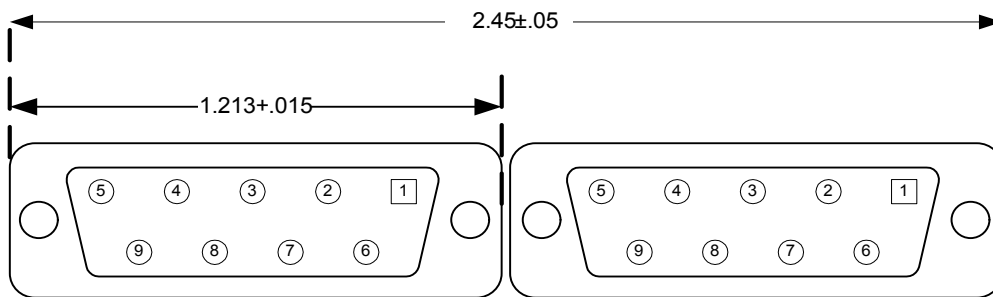

Screw Lock Size for all DB-connectors

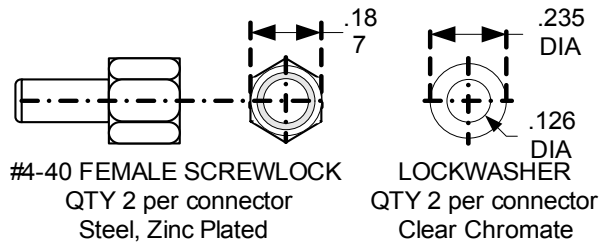

Type of Cable for Encoder Wiring

Low capacitance shielded twisted pair cable is ideal for wiring differential encoders. The better the shield wires, the better the noise immunity to the external equipment wiring. Wiring practice for shielded cables is not an exact science. Different applications will present different sources of noise, and experimentation may be required to achieve the desired results. Therefore, the following recommendations are based upon some experiences that we at Delta Tau Data Systems have acquired.

If possible, the best cabling to use is a double-shielded twisted pair cable. Typically, there are four pairs used in a differential encoder's wiring. The picture below shows how the wiring may be implemented for a typical differential sinusoidal encoder using double shielded twisted pair cable.

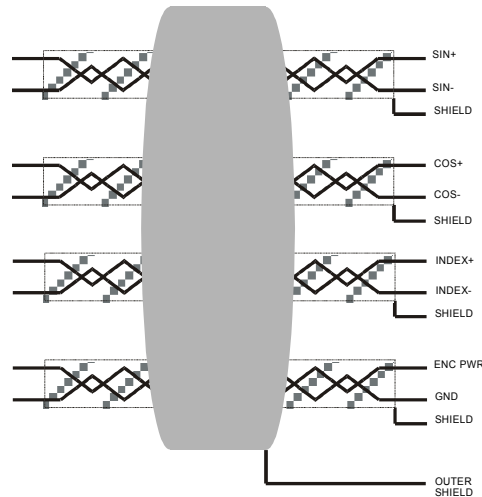

EXAMPLE OF DOUBLE SHIELDED
4 TWISTED PAIR CABLE

The shield wires should be tied to ground (Vcc return) at the interpolator end. It is acceptable to tie the shield wires together if there are not enough terminals available. Keep the exposed wire lengths as close as possible to the terminals on the interpolator.

Note:

It has been observed that there is an inconsistency in the shielding styles that are used by different encoder manufacturers.

Be sure to check pre-wired encoders to ensure that the shield wires are not connected at the encoder's side. Shield wires should be connected only on one side of the cable.

If the encoder has shield wires that are connected to the case ground of the encoder, ensure that the encoder and motor cases are sufficiently grounded. Do not connect the shield at the interpolator end.

If the encoder has pre-wired double shielded cable that has only the outer shield connected at the encoder, then connect only the inner shield wires to the interpolator. Be sure not to mix the shield interconnections.

One possible cable type for encoders is Belden 8164 or ALPHA 6318. This is a 4-pair individually shielded cable that has an overall shield. This double-shielded cable has a relatively low capacitance and is a 100Ω impedance cable.

Cables for single-ended encoders should be shielded for the best noise immunity. Single-ended encoder types cannot take advantage of the differential noise immunity that comes with twisted pair cables.

Note:

If noise is a problem in the application, careful attention must be given to the method of grounding that is used in the system. Amplifier and motor grounding can play a significant role in how noise is generated in a machine.

Noise may be reduced in a motor-based system by the use of inductors placed between the motor and the amplifier.

APPENDIX B

Schematics

X15: Watchdog

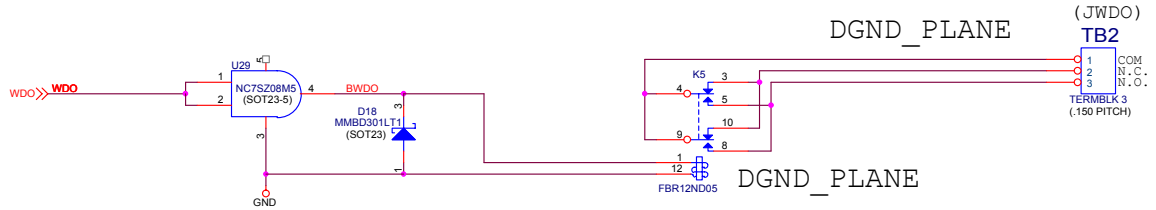

J6 and J7: General Purpose I/O

Inputs

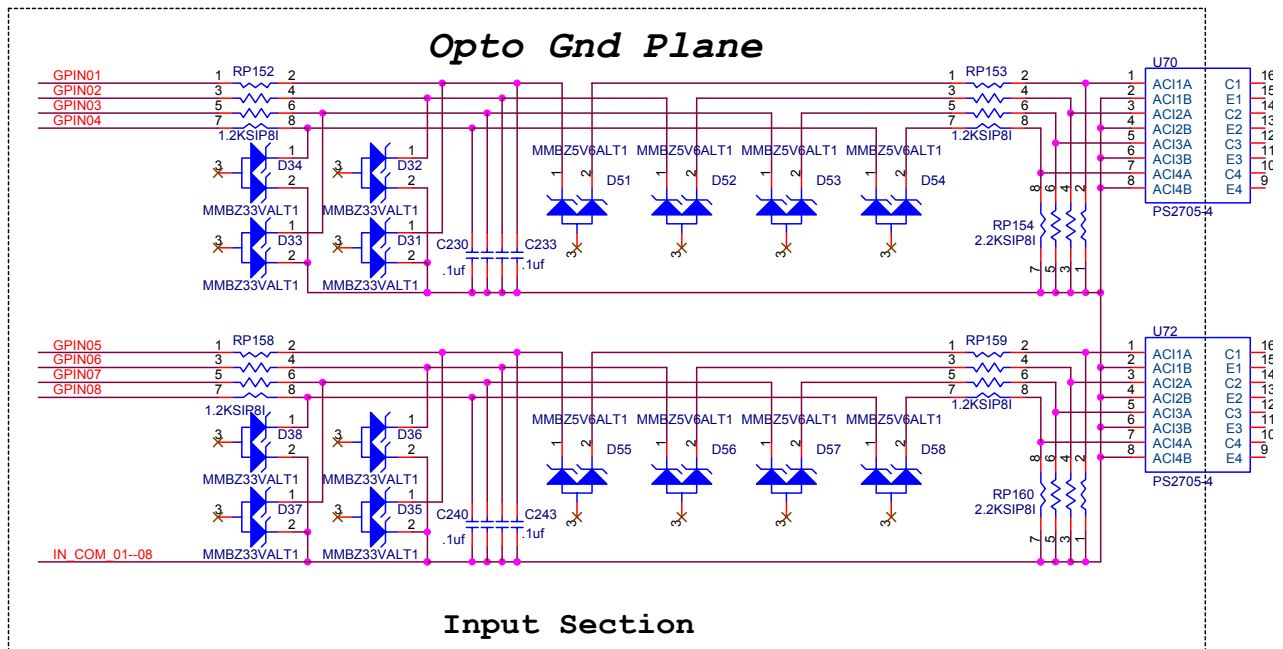

Outputs

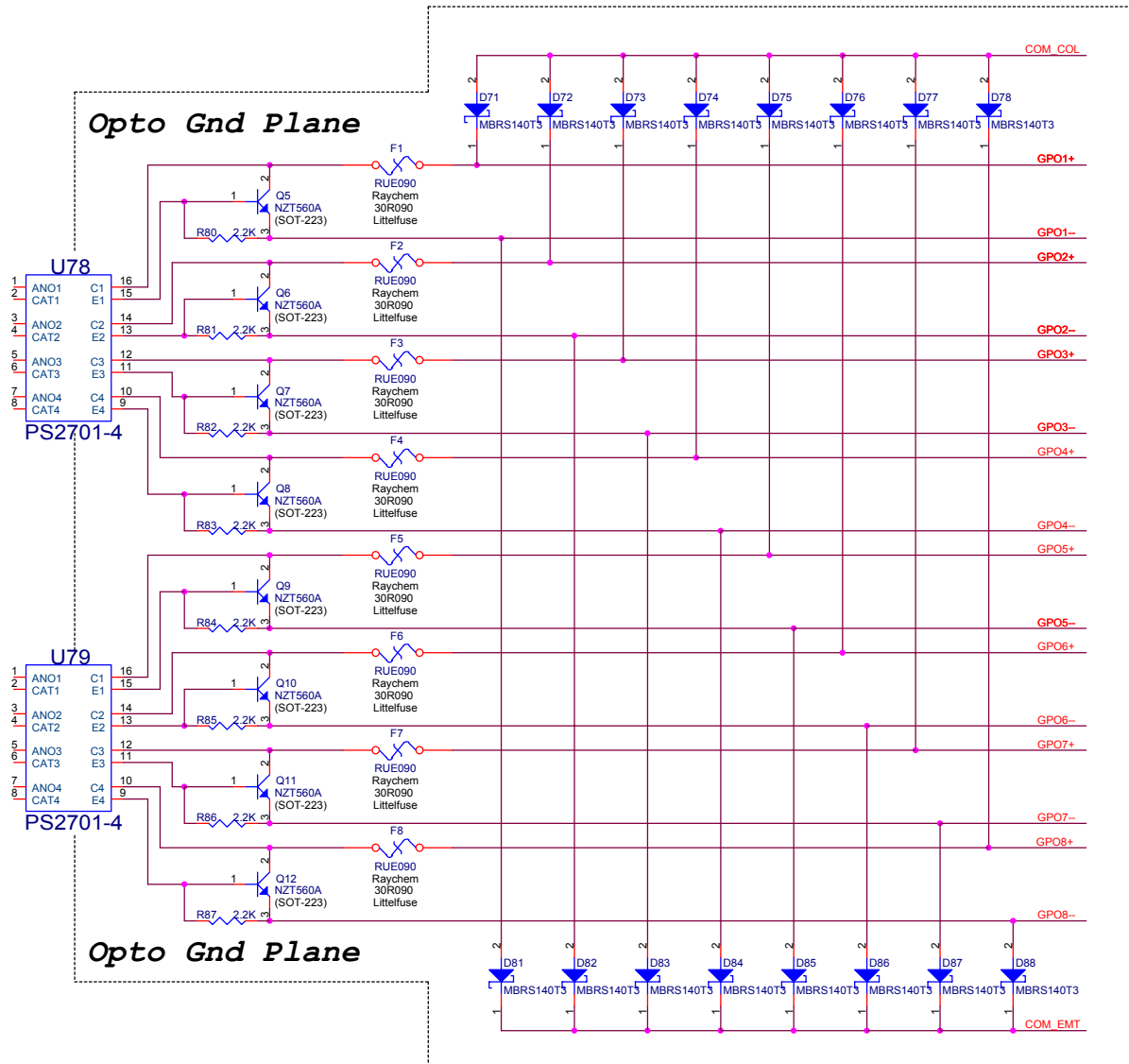

J4: Limit Inputs for Axis 1-4

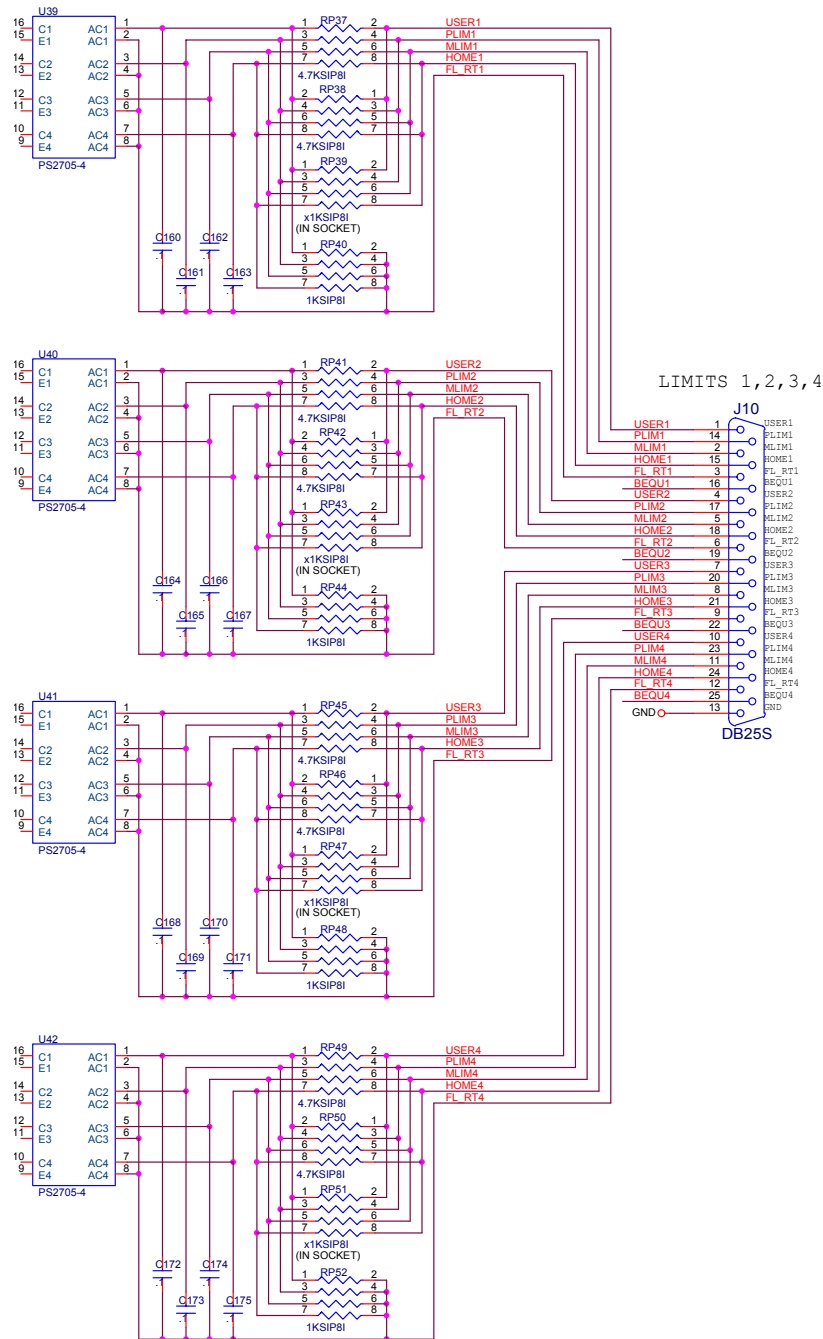

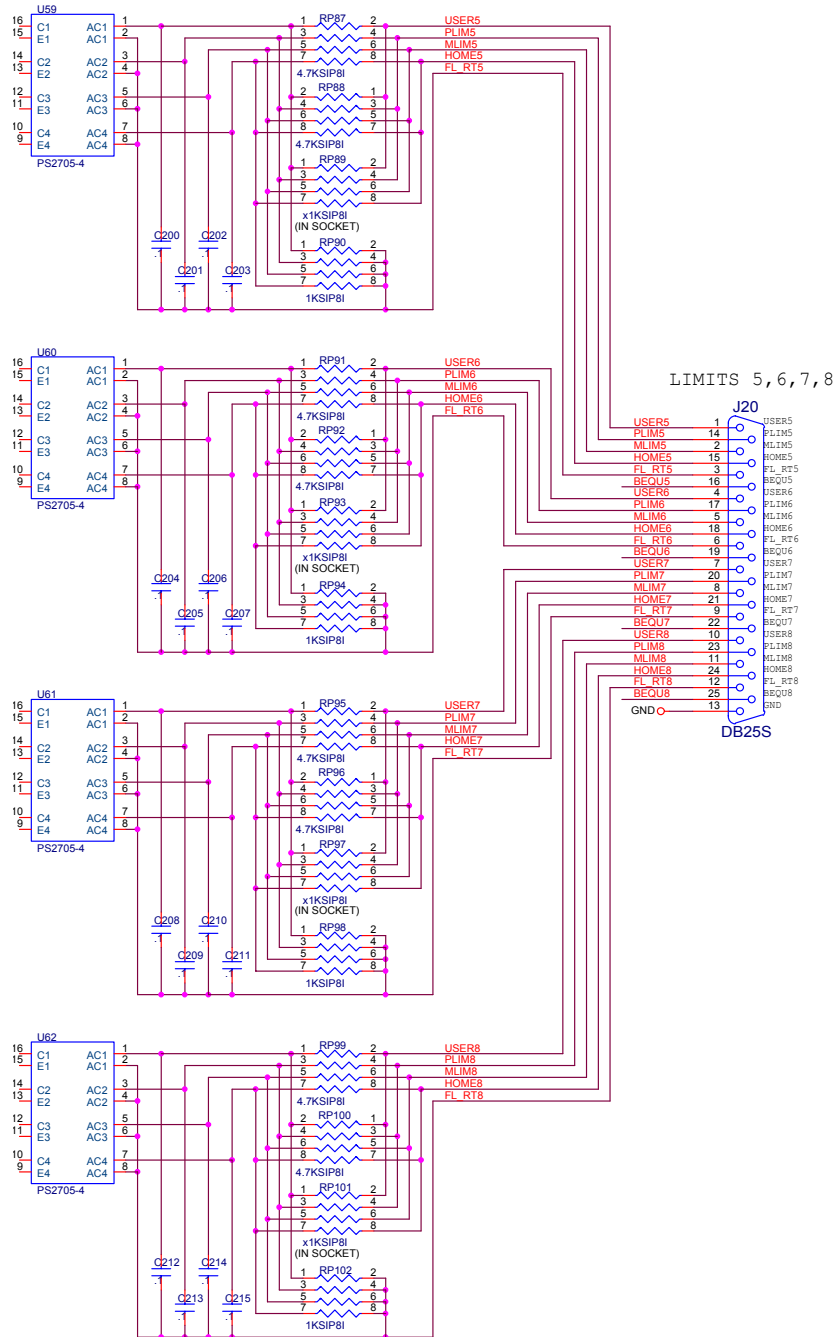

J5: Limit Inputs for Axis 5-8



APPENDIX C

Board Jumpers

E10 – E12: Power-Up/Reset Load Source

E Point & Physical Layout	Description	Default
E10: 	To load active memory from flash IC on power-up/reset/remove jumper E10; Jump E11 pin 1 to 2 Jump E12 pin 1 to 2.	No E10 jumper installed E11 and E12, jump pin 1 to 2.
E11: 	Other combinations are for factory use only; the board will not operate in any other configuration.	
E12: 		





E13: Firmware Reload Enable

E Point and Physical Layout	Description	Default
	Install jumper to reload firmware through the communications port. Remove jumper for normal operations.	No jumper installed





E14: Watchdog Disable Jumper

E Point and Physical Layout	Description	Default
	Jump pin 1 to 2 to disable Watchdog timer (for test purposes only). Remove jumper to enable Watchdog timer.	No jumper installed

E25-28: Select Encoder Index input or AENA output (channels 1-4)

E Point and Physical Layout	Description	Default
E25: 	No Jumper for TTL Level input for Ch1 Index signal (C) Jumper 1-2 to output AENA1 at Ch1 encoder connector	No jumper installed
E26: 	No Jumper for TTL Level input for Ch2 Index signal (C) Jumper 1-2 to output AENA2 at Ch2 encoder connector	No jumper installed
E27: 	No Jumper for TTL Level input for Ch3 Index signal (C) Jumper 1-2 to output AENA3 at Ch3 encoder connector	No jumper installed
E28: 	No Jumper for TTL Level input for Ch4 Index signal (C) Jumper 1-2 to output AENA4 at Ch4 encoder connector	No jumper installed

E35-39: Select Encoder Index input or AENA output (channels 5-8)

E Point and Physical Layout	Description	Default
E35: 	No Jumper for TTL Level input for Ch5 Index signal (C) Jumper 1-2 to output AENA5 at Ch5 encoder connector	No jumper installed
E36: 	No Jumper for TTL Level input for Ch6 Index signal (C) Jumper 1-2 to output AENA6 at Ch6 encoder connector	No jumper installed
E37: 	No Jumper for TTL Level input for Ch7 Index signal (C) Jumper 1-2 to output AENA7 at Ch7 encoder connector	No jumper installed
E38: 	No Jumper for TTL Level input for Ch8 Index signal (C) Jumper 1-2 to output AENA8 at Ch8 encoder connector	No jumper installed

On the revisions of the Geo Brick that the S1- Reset button was not on the face plate

E3: Re-Initialization on Reset Control

E Point and Physical Layout	Description	Default
	Remove jumper for normal reset mode (default). Jump pins 1 to 2 for re-initialization on reset.	No jumper installed