



Parker Automation Actuator Division is pleased to introduce the Value Series Rodless Linear Actuator. Expanding on the ER, the new ERV was designed with an external carriage containing outboard roller bearing support for higher loads. The actuator is designed to directly interface with our structural framing, providing a simple and cost effective solution for single or multiple-axis systems.

PERFORMANCE OVERVIEW

- Two sizes: 5, 8
- Carriage loads to 4480 N
- Extended carriage option
- Speeds up to 5m/sec
- Repeatability: $\pm 0.102\text{mm}$
- Strokes to 6 meters
- Internal drive belt

	ERV5		ERV8	
	Standard Carriage	Extended Carriage	Standard Carriage	Extended Carriage
Carriage Weight (N)	8.0	13.8	16.3	24.8
Mass Moment of Inertia (kg-cm ²)	3.6	5.4	16.9	23.5
Body Moment of Inertia – X Axis (cm ⁴)	68.05	68.05	224.5	224.5
Body Moment of Inertia – Y Axis (cm ⁴)	67.12	67.12	222.3	222.3
Moment of Elasticity (N/mm ²)	68,950	68,950	68,950	68,950
Zero Stroke Unit Weight (N)	35.6	40.9	80.5	89.9
Weight per 100mm of Length (N)	4.0	4.0	7.2	7.2
Pulley Diameter (mm)	30.6	30.6	46.6	46.6
Linear Travel per Revolution (mm)	96.1	96.1	146.2	146.2
Maximum Travel (mm)*	5886.0	5746.0	5846.0	5721.0
Maximum Drive Torque (Nm)	11.2	11.2	18.6	18.6
Maximum Belt Traction (N)**	732	732	957	957
Maximum Speed (m/s)	5.0	5.0	5.0	5.0
Maximum Acceleration at No Load (m/s ²)	10.0	10.0	10.0	10.0
Repeatability (mm)	± 0.10	± 0.10	± 0.10	± 0.10

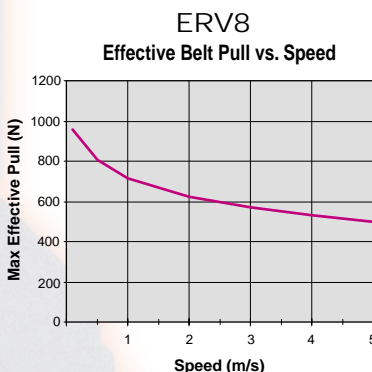
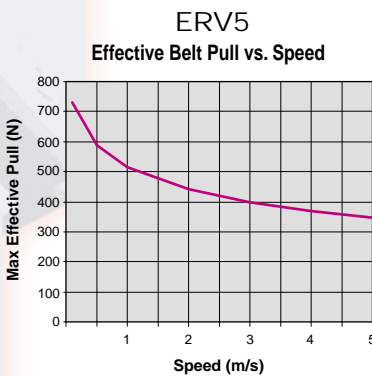

*Consult factory for longer travel lengths.
**Consult factory for increased belt traction force.

Successful factory automation solutions begin with products that are engineered and manufactured to deliver the widest range of performance characteristics. AAD has over 26,000 different part numbers in its system including electric actuators and cylinders, end effectors and structural framing technologies. All products are manufactured, tested and delivered to meet or exceed customer expectations.

AAD is also well established as a provider of engineering and application expertise in the field of factory automation, and can design, build and test a cost-effective custom system.

Order Example **ERV B 5 BLT R A 23[†] S P B N X 0500 A ★**

★Three digit code assigned by factory when any X, 9 or gearbox appears in the model number, or when special options or features are required.

- Model Series **ERV**
- Drive Type
 - Stepper **S**
 - Brushless Servo **B**
 - Zenith NEN/UTN Gear Box★ **G**
- Frame Size
 - 56mm **5**
 - 80mm **8**
- Drive Style **BLT**
- Drive Mounting Style
 - Direct, Drive Right **R**
 - Direct, Drive Left **L**
 - Parallel*, Over Right** **M**
 - Parallel*, Under Right** **N** * With timing belt
 - Parallel*, Over Left** **S** ** Motor dependent
 - Parallel*, Under Left** **T**
 - Reverse Parallel*, Over Right... **V**
 - Reverse Parallel*, Under Right.. **W**
 - Reverse Parallel*, Over Left **Y**
 - Reverse Parallel*, Under Left ... **Z**
 - Reverse Parallel*, Rear Right... **J**
 - Reverse Parallel*, Rear Left **K**
- Drive Ratio
 - 1:1 **A**
 - 1.5:1** **B**
 - 2:1** **D**
 - AA Gear Drive 1:1** **K**
 - AA Gear Drive 3:1** **E**
 - AA Gear Drive 5:1** **F**
 - AA Gear Drive 7.5:1** **G**
 - AA Gear Drive 10:1** **H**
- Servo Motor (ERVB only)
 - SM233 "T" Shaft Flange & Coupler/Pulley only **20**
 - SM233BE-TTQN Motor **22**
 - SM233BR-TMSN Motor **23**
 - Other AAD Supplied SM233 "T" Shaft Motor★ **2X**
 - SM233AE-TGSN Motor **26**
 - Approved Customer SM233 "T" Shaft Motor★ **29**
 - ML3450B Flange & Coupler/Puller Only **30**
 - Other AAD Supplied ML3450B Motor★ **3X**
 - Approved Customer ML3450B Motor★ **39**
 - No Motor (Mounting Only), Based on J092 **J0**
 - Customer Supplied Parker Motor★ **J9**
 - Other AAD Supplied Motor★ **JX**
 - J0922JR-KMSN **J1**
 - J0923HR-KMSN **J2**
 - J0923KR-KMSN **J3**
 - BE23 "K" Shaft Flange & Coupler/Pulley Only **L0**
 - Customer Supplied BE23 "K" Shaft Motor★ **L9**
 - Other AAD Supplied BE23 "K" Shaft Motor★ **LX**
 - BE34, N034, J034 "K" Shaft Flange & Coupler/Pulley **N0**
 - Customer Supplied BE34, N034, J034 "K" Shaft Motor★ **N9**
 - Other AAD Supplied BE34, N034, J034 "K" Shaft★ ... **NX**
 - Special Motor Flange & Coupler/Pulley **90**
 - Special Customer Motor Mounted at AAD★ **99**

ERVS

† Select the appropriate code based on series.
 ‡ Available on ERVS8 only.

ERVG

- Design Series
 - Current Design **A**
 - Stroke Order in increments of 100mm **xxxx**
- Brake Option
 - Consult Factory **X**
 - None **N**
- Options
 - None **N**
 - Carriage Options
 - Wipers **W**
 - Bumpers **B**
 - Wipers and Bumpers **Y**
 - None **N**
 - Normal Carriage Loading
 - Positive (Toward Actuator) **P**
 - Negative (Away from Actuator) **G**
 - Carriage Style
 - Standard **S**
 - Extended **L**
- Step Motor Option (ERVS only)
 - 20** S57-xxx Flange and Coupler/Pulley Only
 - 21** S57-102 with Cable Grommet
 - 22** S57-102 with Conduit Connector
 - 23** S57-102 with Brad Harrison Connector and 4m Cable
 - 29** Customer Supplied Parker Motor★
 - 2X** Other AAD Supplied S57-xxx Motor★
 - 30** S83-xxx Flange and Coupler/Pulley Only
 - 31** S83-135 with Cable Grommet
 - 32** S83-135 with Conduit Connector
 - 33** S83-135 with Brad Harrison Connector and 4m Cable
 - 39** Customer Supplied Parker Motor★
 - 3X** Other AAD Supplied S83-xxx Motor★
 - 40[†]** S106-xxx Flange and Coupler/Pulley Only
 - 41[†]** S106-178 with Cable Grommet
 - 42[†]** S106-178 with Conduit Connector
 - 43[†]** S106-178 with Brad Harrison Connector and 4m Cable
 - 49** Customer Supplied Parker Motor★
 - 4X[†]** Other AAD Supplied S106-xxx Motor★
- Gearboxes (ERVG only)
 - Prepped for EMRZ-UTN060 **AO**
 - AA Purchased EMRZ-UTN060, Mounted★ **AX**
 - Customer Supplied EMRZ-UTN060, Mounted★ **A9**
 - Prepped for EMRZ-UTN092 **BO**
 - AA Purchased EMRZ-UTN092, Mounted★ **BX**
 - Customer Supplied EMRZ-UTN092, Mounted★ **B9**

LOADING

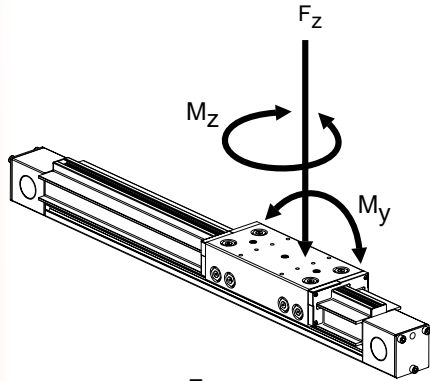

Static Moment Loads

Determine which moment loads are induced by the static load. Locate the center of gravity of the load and the length of the moment arm.

Moment Arm Lengths

Determine the moment arm lengths associated with each moment load by measuring the distance from the center of the load to the center of the carriage in each moment load direction.

Pitch Moment

When determining the pitch moment arm, it is necessary to consider the distance from the top of the load attachment plate to the center of the carriage bearings. For the ERV5 Series, this distance is 40mm.

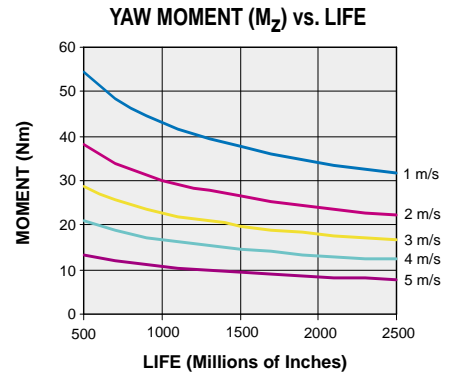
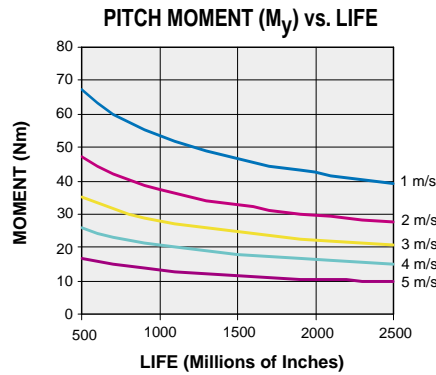
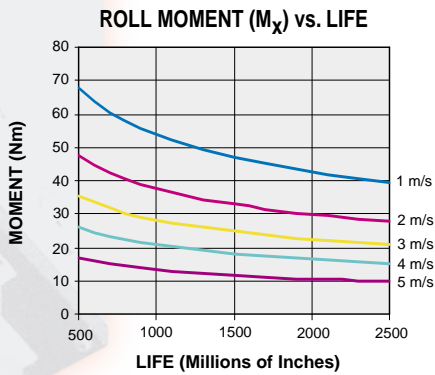
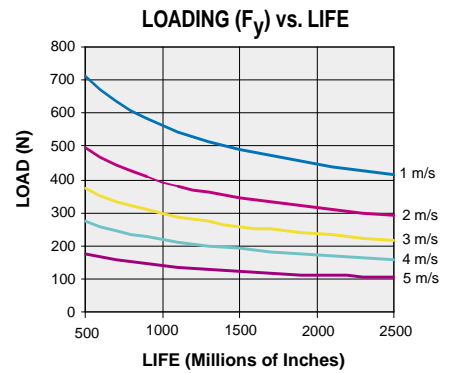
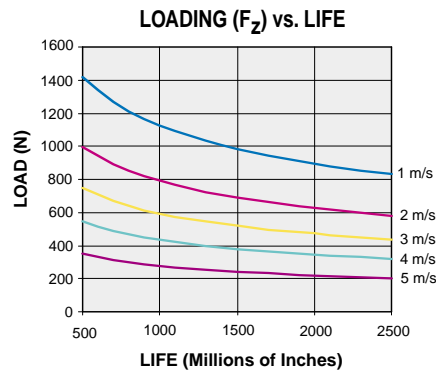

DEFLECTION

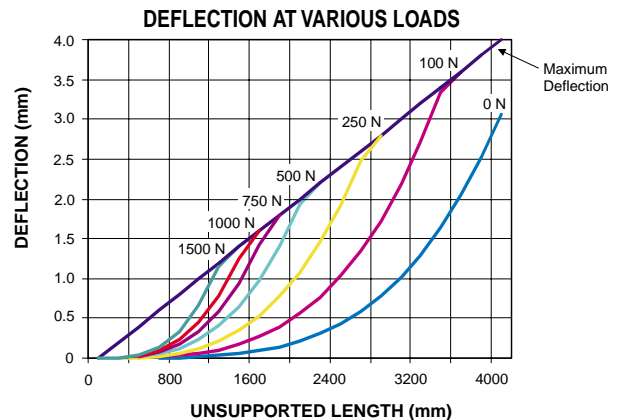
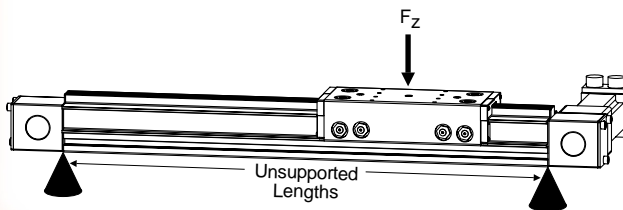

Static Moment Loads

Determine which moment loads are induced by the static load. Locate the center of gravity of the load and the length of the moment arm.

Moment Arm Lengths

Determine the moment arm lengths associated with each moment load by measuring the distance from the center of the load to the center of the carriage in each moment load direction.

Pitch Moment

When determining the pitch moment arm, it is necessary to consider the distance from the top of the load attachment plate to the center of the carriage bearings. For the ERV8 Series, this distance is 47mm.

LOADING

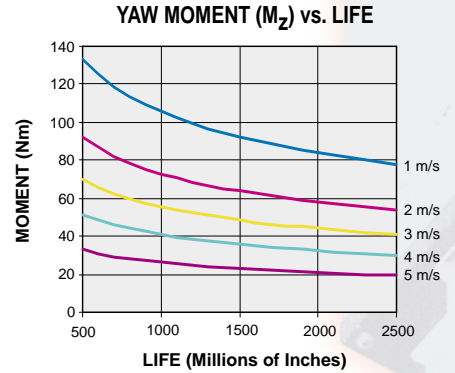
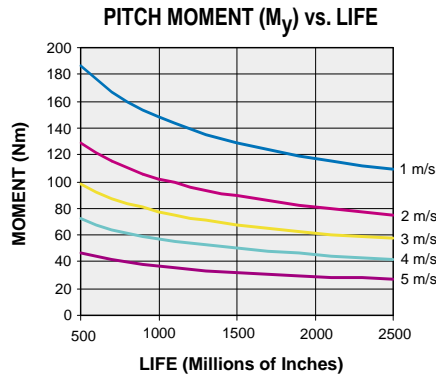
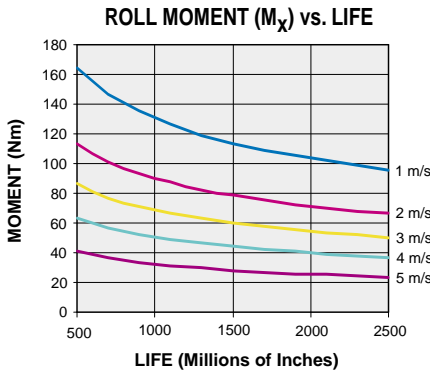
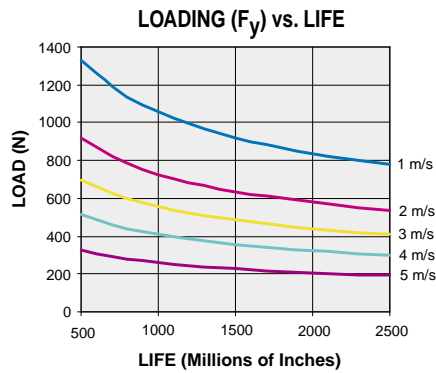
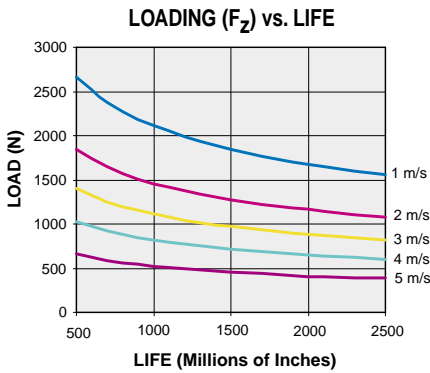
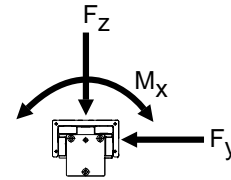
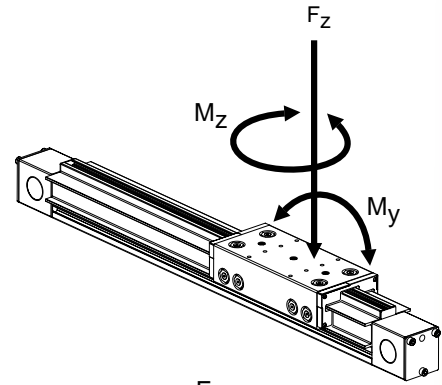

DEFLECTION

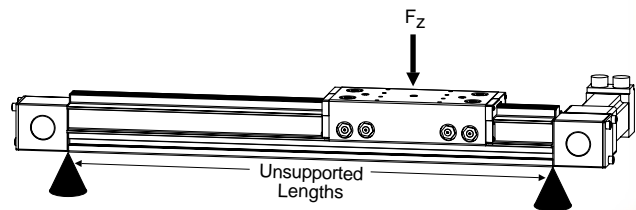
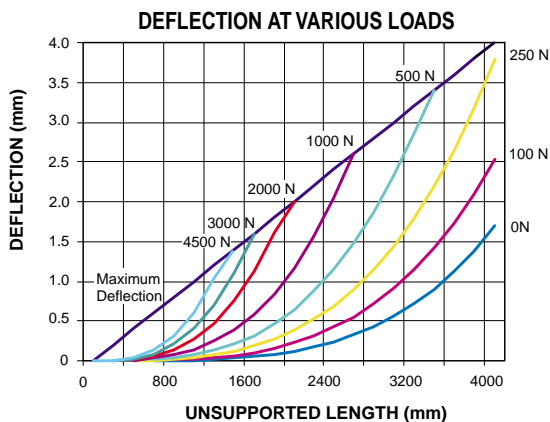

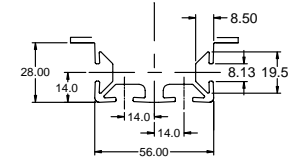
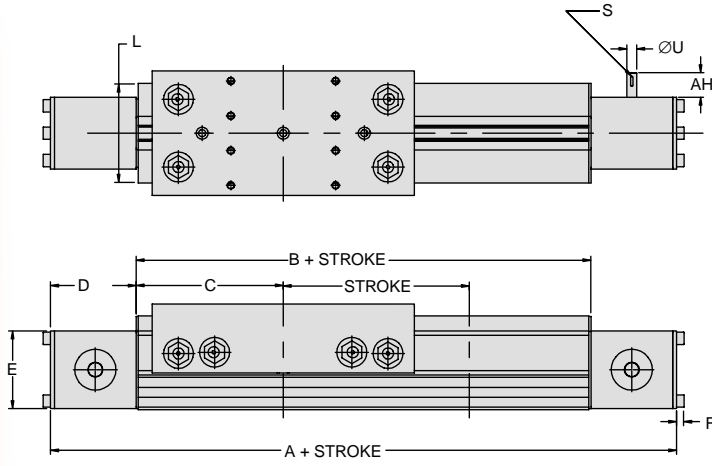

MOUNTING DETAIL 5

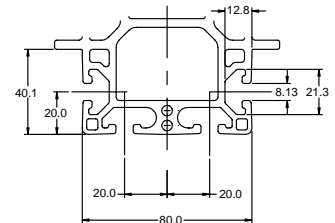
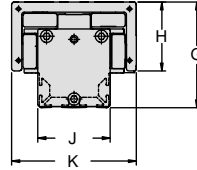

MOUNTING DETAIL 8

Size	Carriage	Option	A	B*	C
5	Standard	w/o bumpers	369.8	232.5	116.2
		w/ bumpers	470.8	333.5	166.7
	Extended	w/o bumpers	509.8	372.5	186.2
		w/ bumpers	610.8	473.5	236.7
8	Standard	w/o bumpers	473.8	272.5	136.2
		w/ bumpers	587.3	385.5	193.0
	Extended	w/o bumpers	598.8	397.5	198.7
		w/ bumpers	712.3	510.5	255.5

NOTE: Felt wipers do not increase A, B or C dimensions.

Size	D	E	F	G	H	J	K	L	U	AH	S
5	68.7	62.5	6.0	85.0	55.5	58.0	100.0	80.0	7.96	19.7	M2 X 8
8	100.7	84.0	6.0	110.0	67.5	80.0	130.0	106.0	13.95	32.0	M5 X 14

* Dimension is referenced from hard stop to hard stop.

CARRIAGE MOUNTING DETAIL

Size 5 Standard Carriage

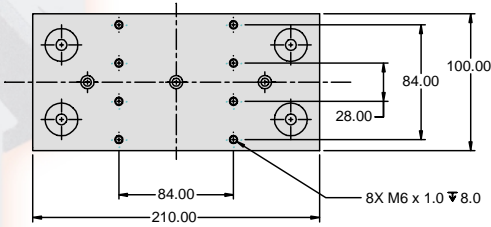

Size 5 Extended Carriage

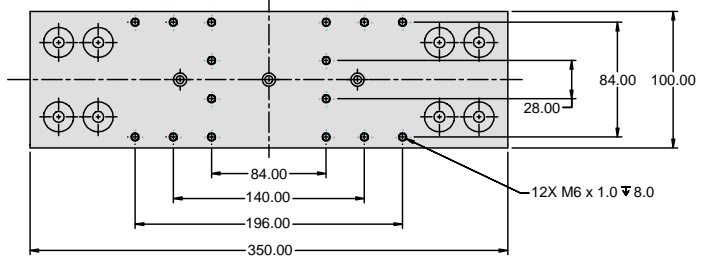

Size 8 Standard Carriage

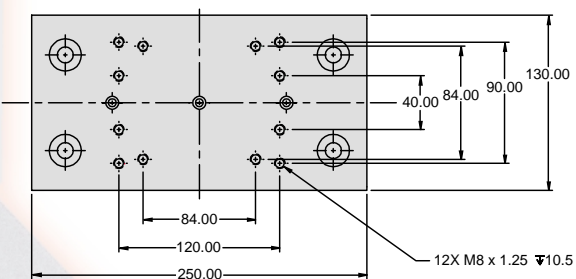

Size 8 Extended Carriage

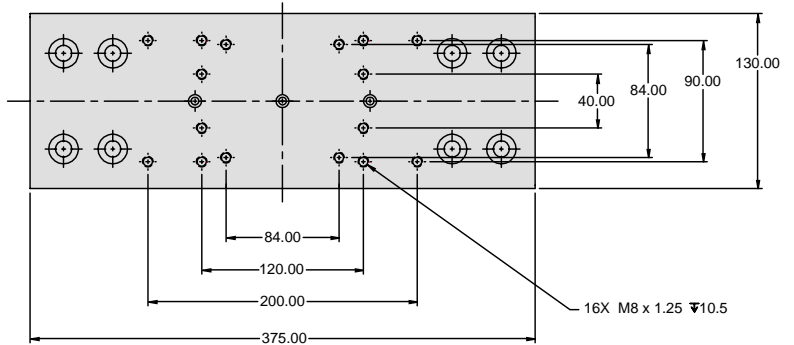

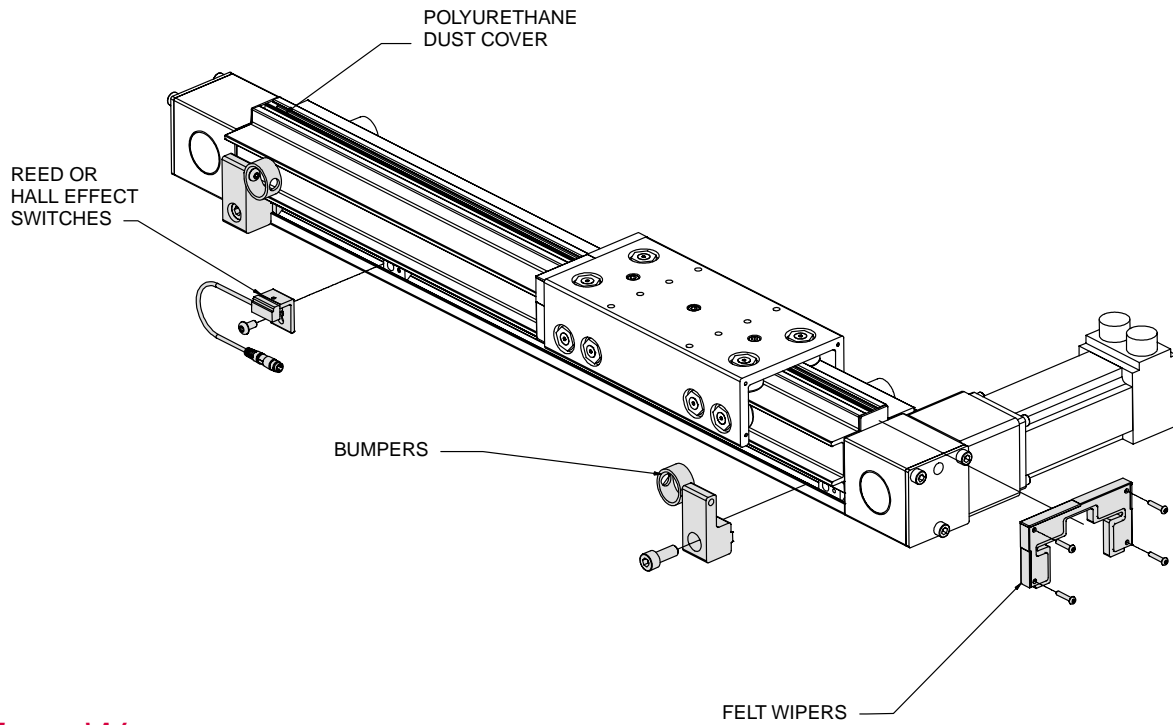

FELT WIPERS

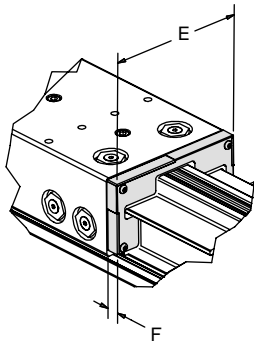

The felt wiper option is designed to prevent contaminants from entering the carriage assembly.

Size	E	F
5	99	9.5
8	129	9.5

BUMPERS

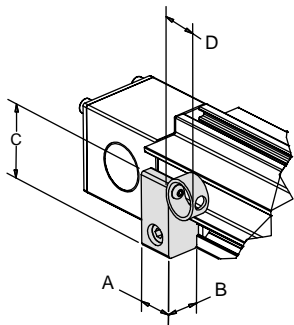

Optional bumpers are designed to prevent over-travel and can be adjusted along the full length of travel. The bumpers are fixed to the actuator extrusion via a standard T-slot (M8 SHCS and T-nut).

Size	A	B	C	D
5	25.4	23.9	52.5	25.1
8	25.4	30.3	71	31.1

SWITCHES

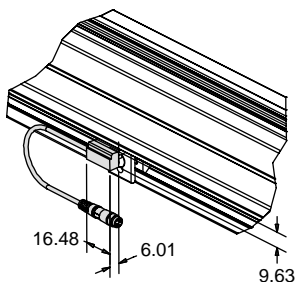

Part No.**	Type	LED Color	Logic	Cable/Connector
SMHnn-1P	N.O.	Green	PNP	1.5m Black with Leads
SMHnn-1N	N.O.	Red	NPN	
SMCnn-1P	N.C.	Yellow	PNP	
SMCnn-1N	N.C.	White/Red	NPN	150mm Black with Connector*
SMHnn-1PC	N.O.	Green	PNP	
SMHnn-1NC	N.O.	Red	NPN	
SMCnn-1PC	N.C.	Yellow	PNP	
SMCnn-1NC	N.C.	White/Red	NPN	

* Sensor cable assemblies purchased separately.

** nn = V5 to fit ERV5 or V8 to fit ERV8

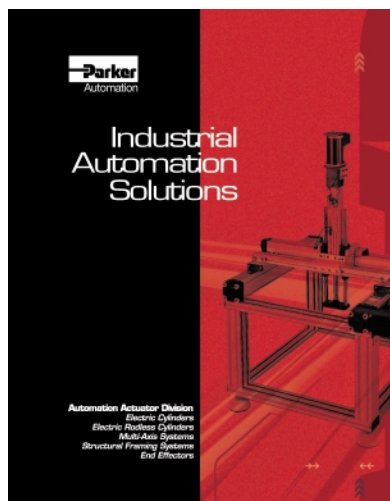

1-330-336-3511
 AADsales@parker.com

For more information on AAD's systems
 or for a free overview catalog.

www.parker.com/automation

Parker's extensive web site offers the most up-to-date product information and additional resources. It is the industry's most comprehensive site and includes product data, downloadable catalogs, contact information, training materials, product selection software and live order capabilities.

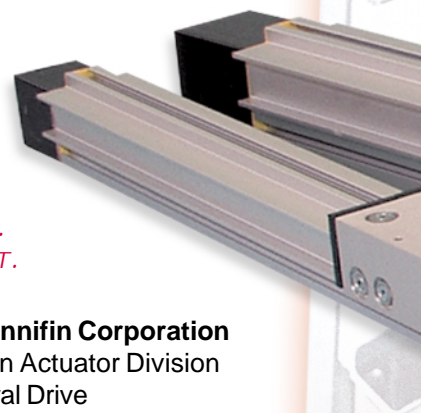

THINK IT.
 DESIGN IT.
 BUILD IT.

Parker Hannifin Corporation
 Automation Actuator Division
 135 Quadral Drive
 Wadsworth, OH 44281
 Phone 330-336-3511
 Fax 330-334-3335



⚠ WARNING

FAILURE OR IMPROPER SELECTION OR IMPROPER USE OF THE PRODUCTS AND/OR SYSTEMS DESCRIBED HEREIN OR RELATED ITEMS CAN CAUSE DEATH, PERSONAL INJURY AND PROPERTY DAMAGE.

This document and other information from Parker Hannifin Corporation, its subsidiaries and authorized distributors provide product and/or system options for further investigation by users having technical expertise. It is important that you analyze all aspects of your application and review the information concerning the product or system in the current product catalog. Due to the variety of operating conditions and applications for these products or systems, the user, through its own analysis and testing, is solely responsible for making the final selection of the products and systems and assuring that all performance, safety and warning requirements of the application are met.

The products described herein, including without limitation, product features, specifications, designs, availability and pricing, are subject to change by Parker Hannifin Corporation and its subsidiaries at any time without notice.

Offer of Sale

The items described in this document are hereby offered for sale by Parker Hannifin Corporation, its subsidiaries or its authorized distributors. This offer and its acceptance are governed by the provisions stated in the full "Offer of Sale".